

120 min

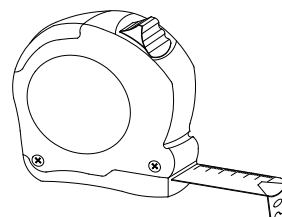

01_01	2000,0	530,0	16,0	1	3/3
01_02	2000,0	530,0	16,0	1	3/3
03_11	1267,0	529,5	16,0	1	1/3
03_12	1267,0	529,5	16,0	1	1/3
03_13	879,0	507,0	16,0	1	1/3
03_14	879,0	507,0	16,0	1	1/3
04_11	1967,0	509,0	16,0	1	3/3
05_11	372,0	504,0	16,0	4	1/3
08_11	1985,0	387,0	16,0	1	2/3
08_12	1533,0	446,5	16,0	2	2/3
08_21	896,0	222,0	16,0	2	1/3
09_11	450,0	170,0	12,0	4	1/3
09_21	830,0	180,0	12,0	2	1/3
10_11	1981,0	388,0	3,0	1	2/3
10_12	1981,0	446,0	3,0	2	2/3
10_21	854,0	453,0	3,0	2	2/3

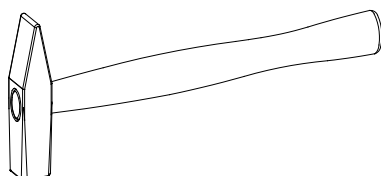

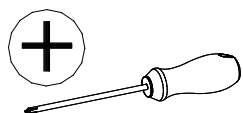
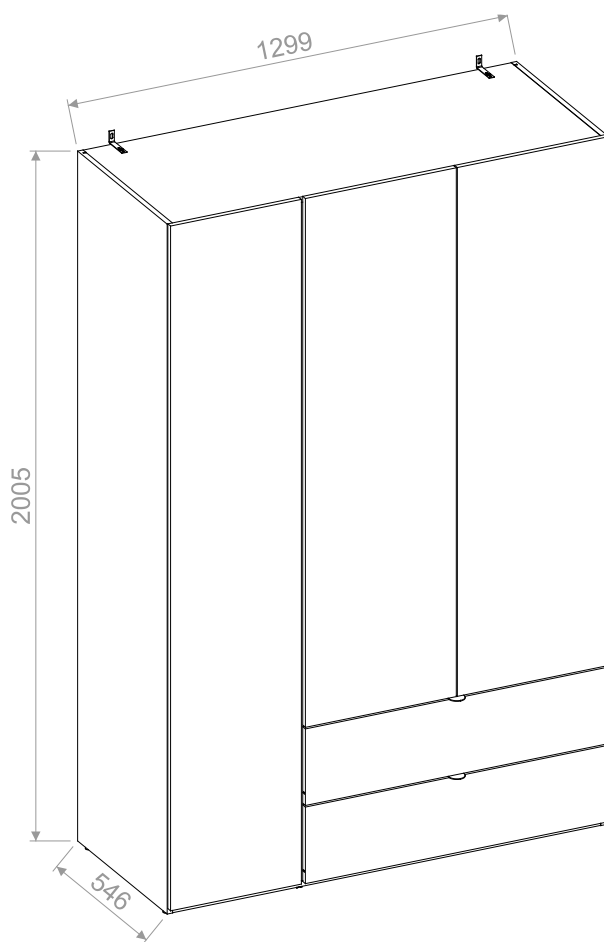
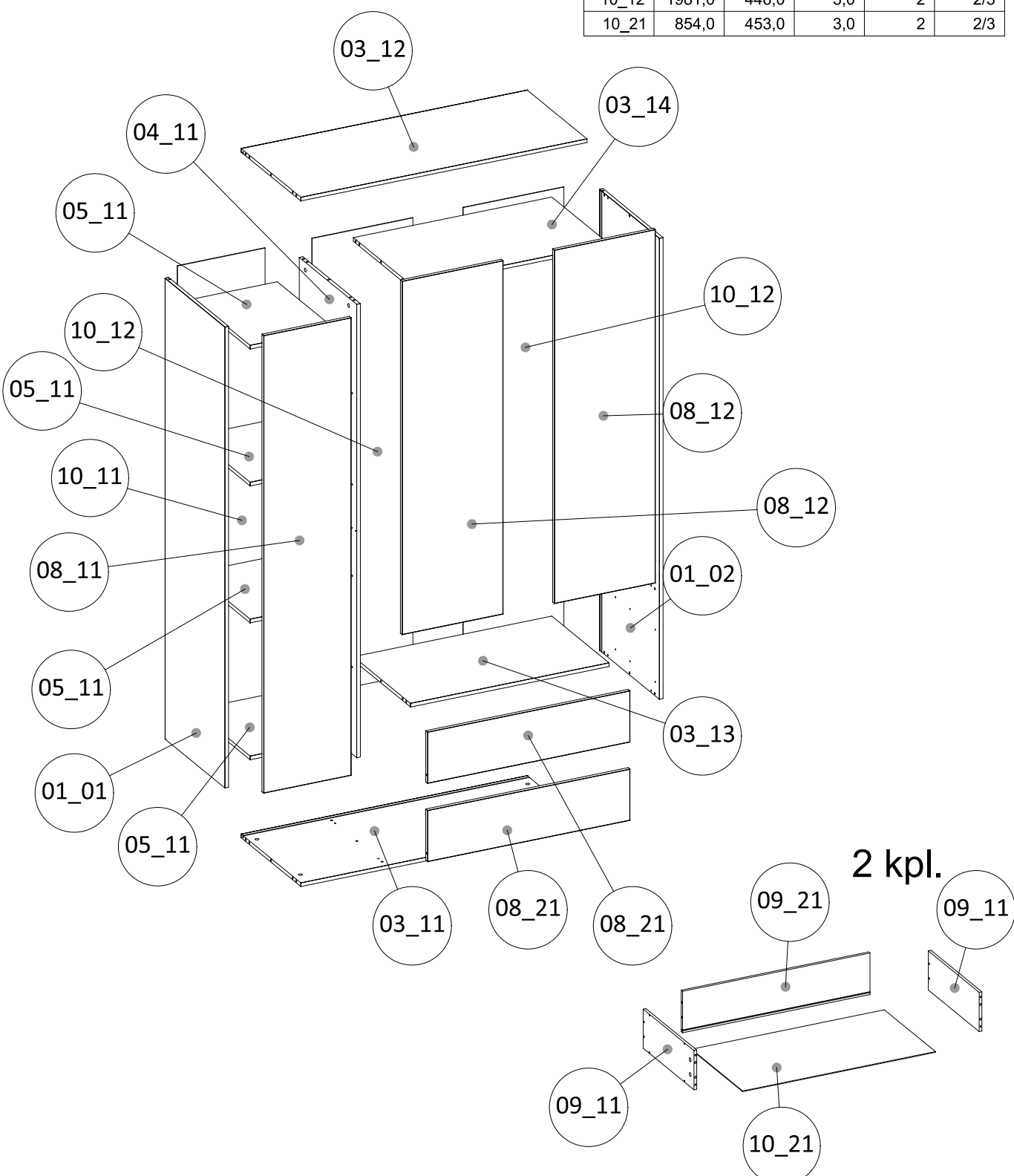
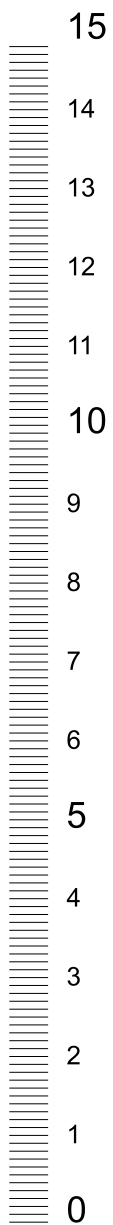
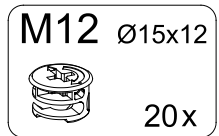
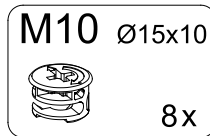
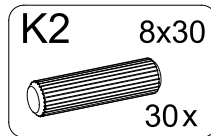
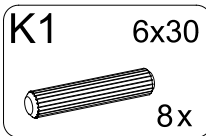
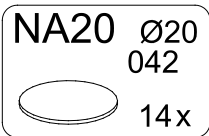
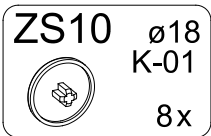
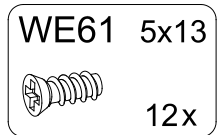
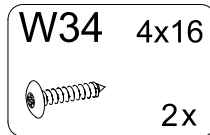
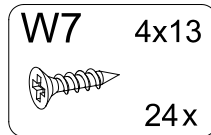
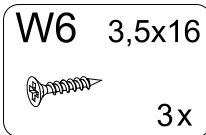
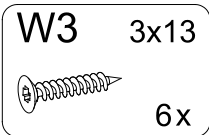
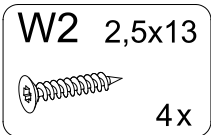
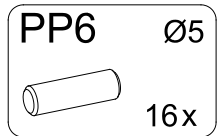
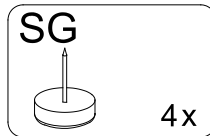
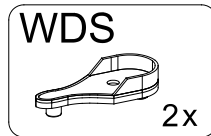
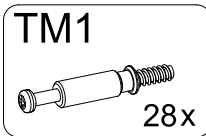
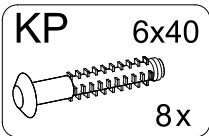
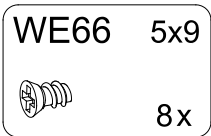
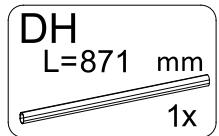
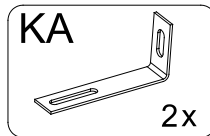
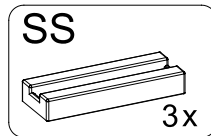
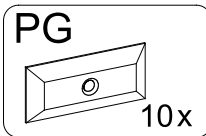
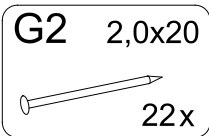
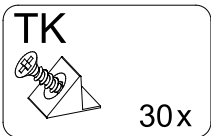
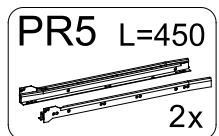
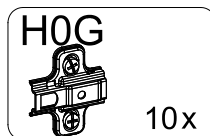
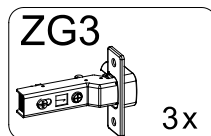
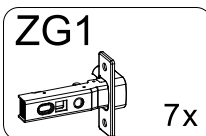
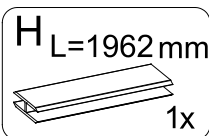
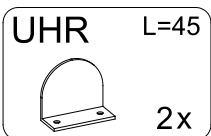
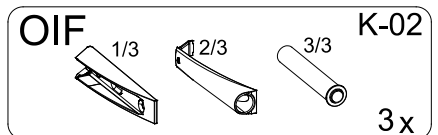
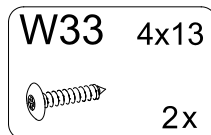
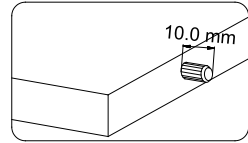
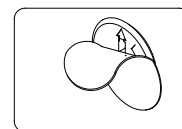
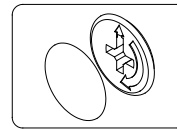
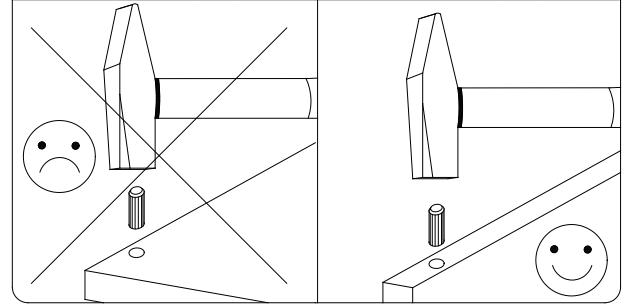
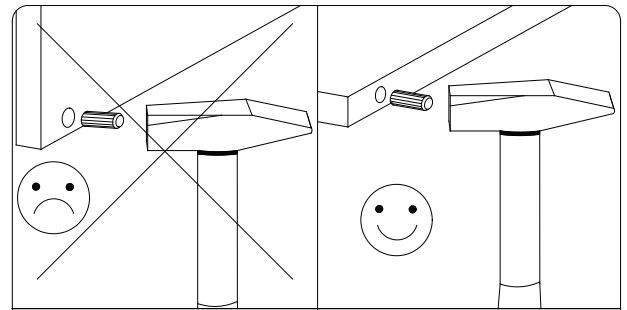
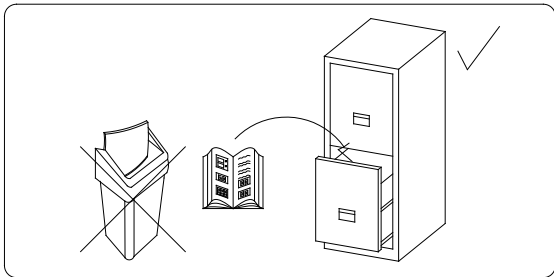
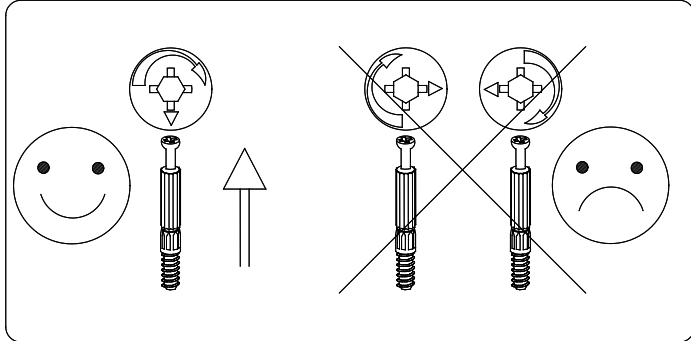
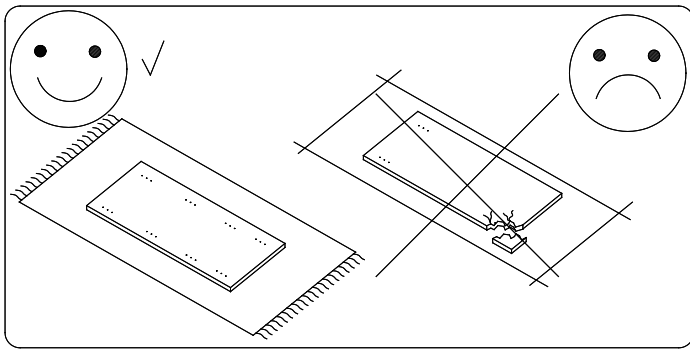

1

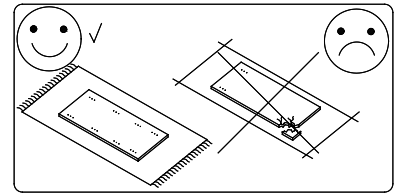
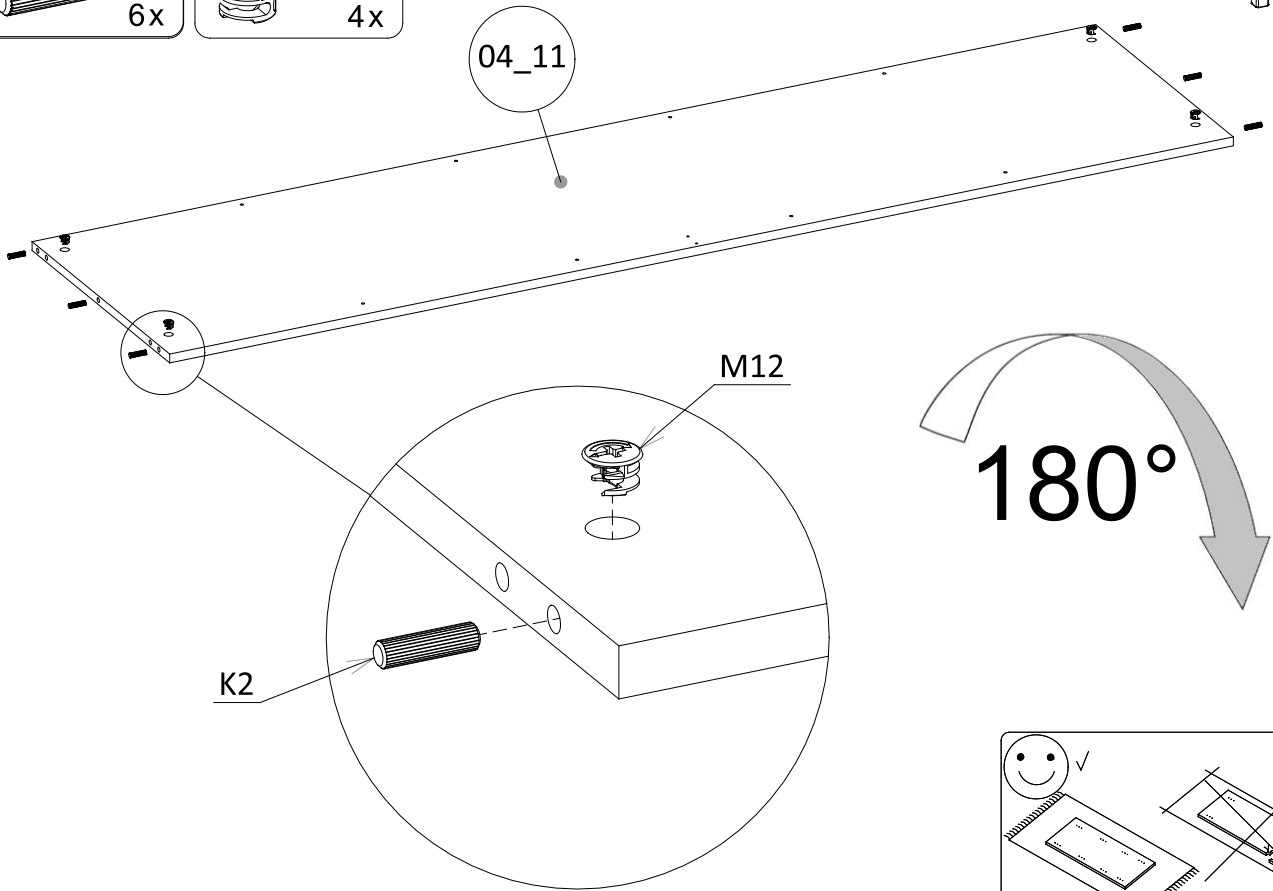
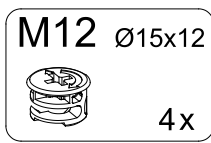
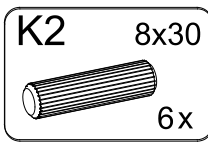

2

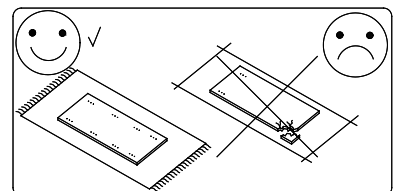
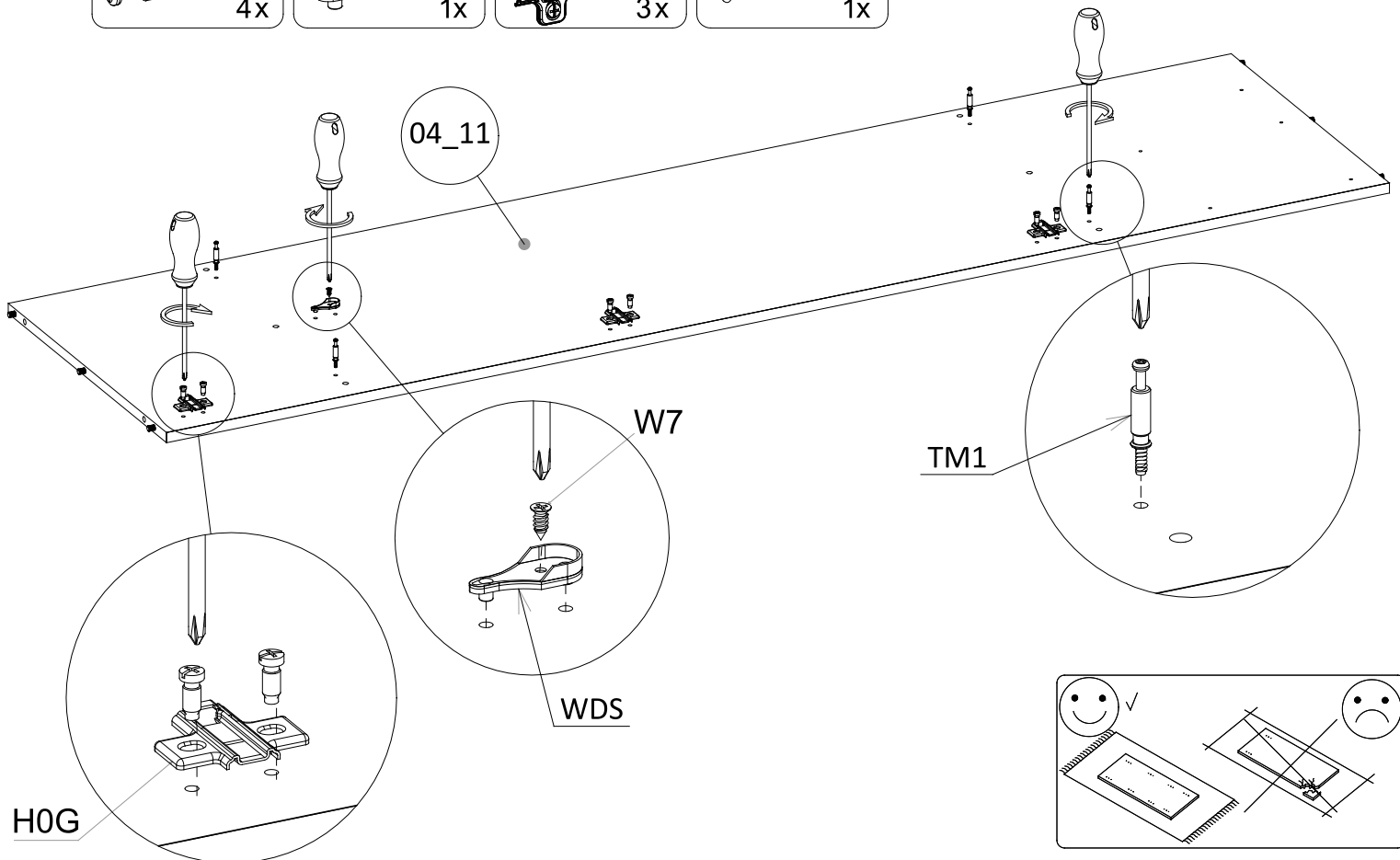
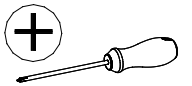
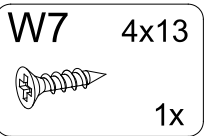
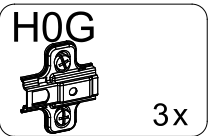
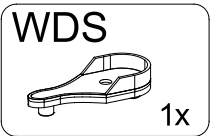
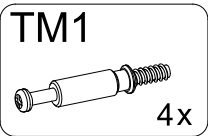

3

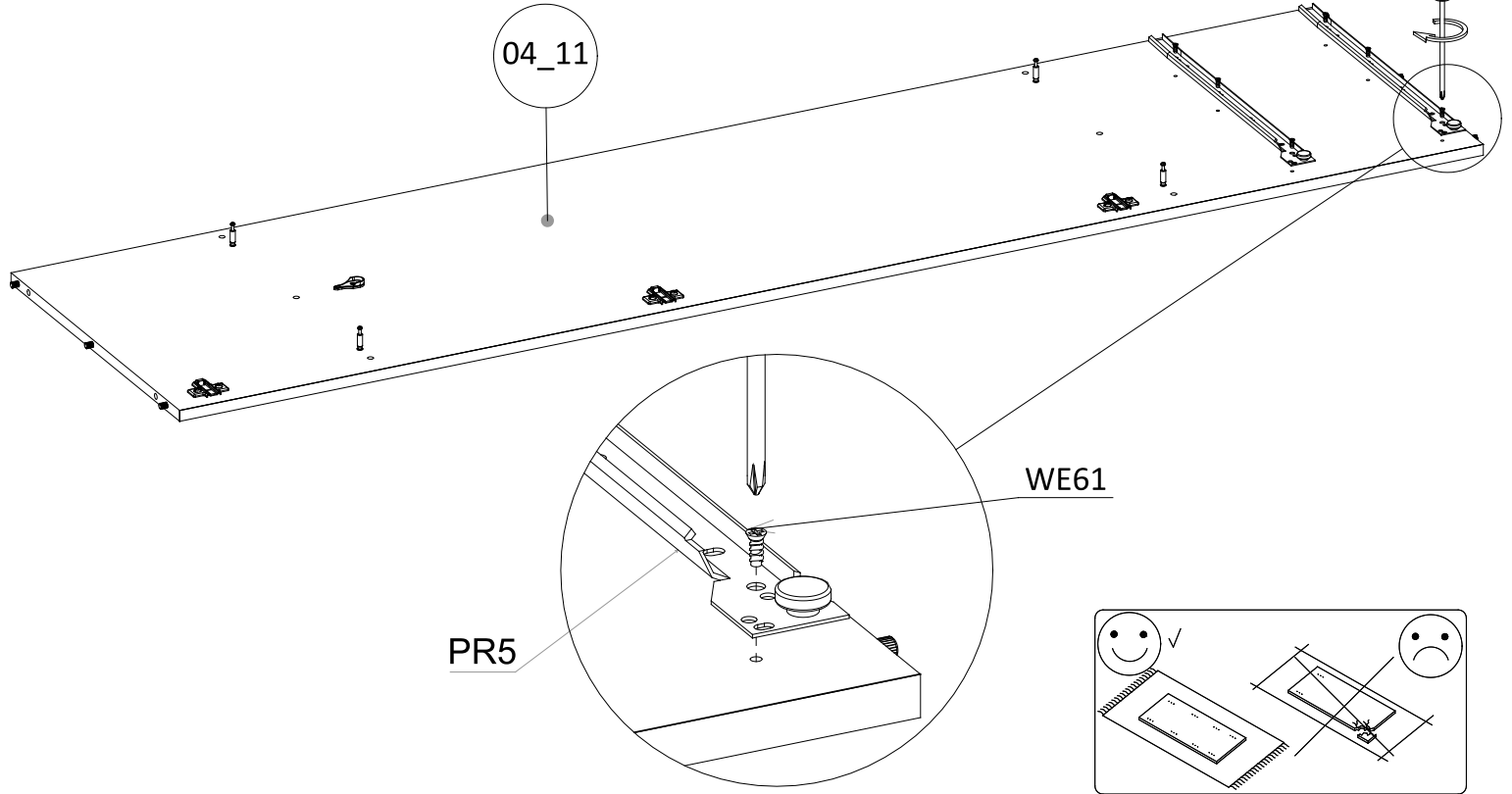
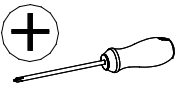
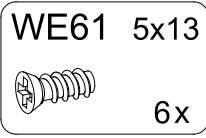
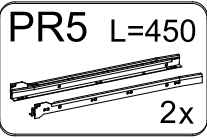

4

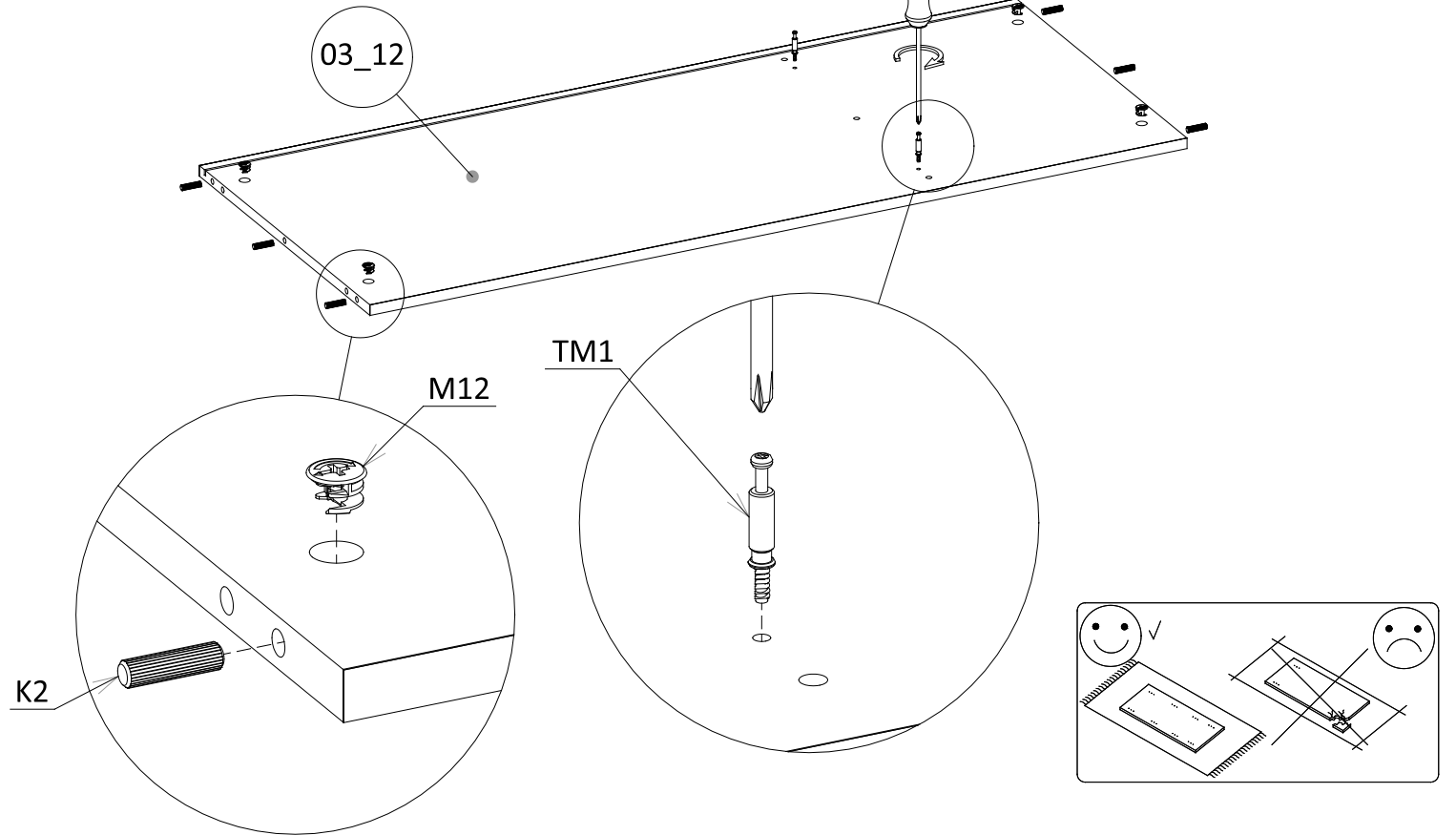
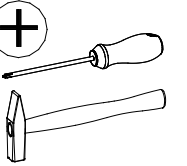
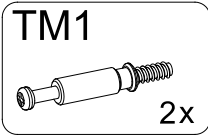
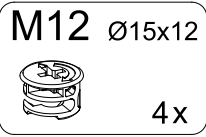
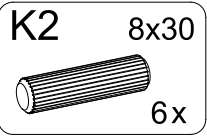

5

NA20 Ø20
042
2x

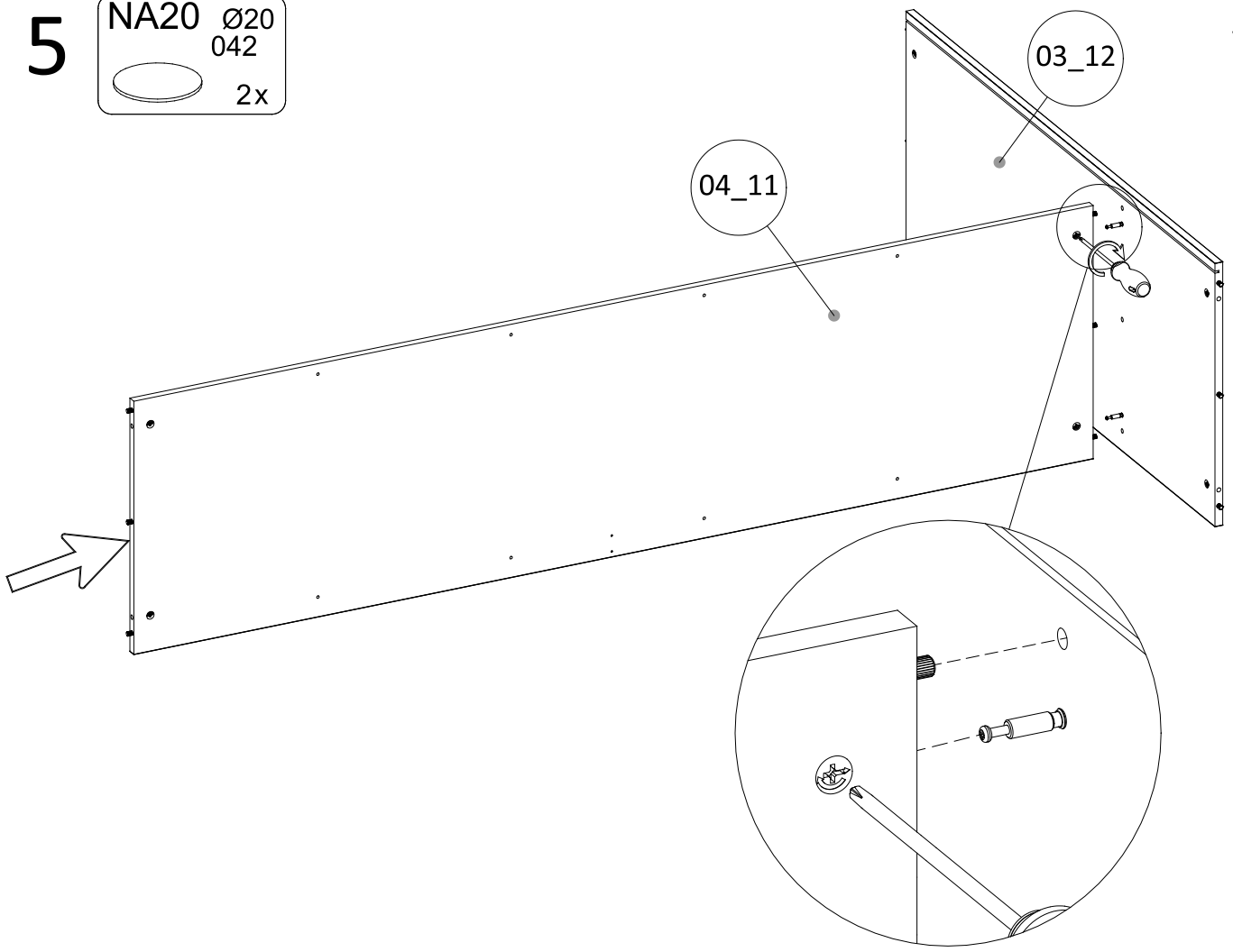
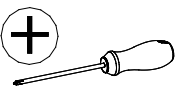

6

K2 8x30 6x
M12 Ø15x12 4x
TM1 2x

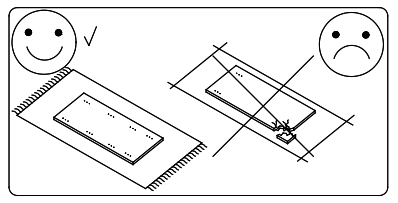
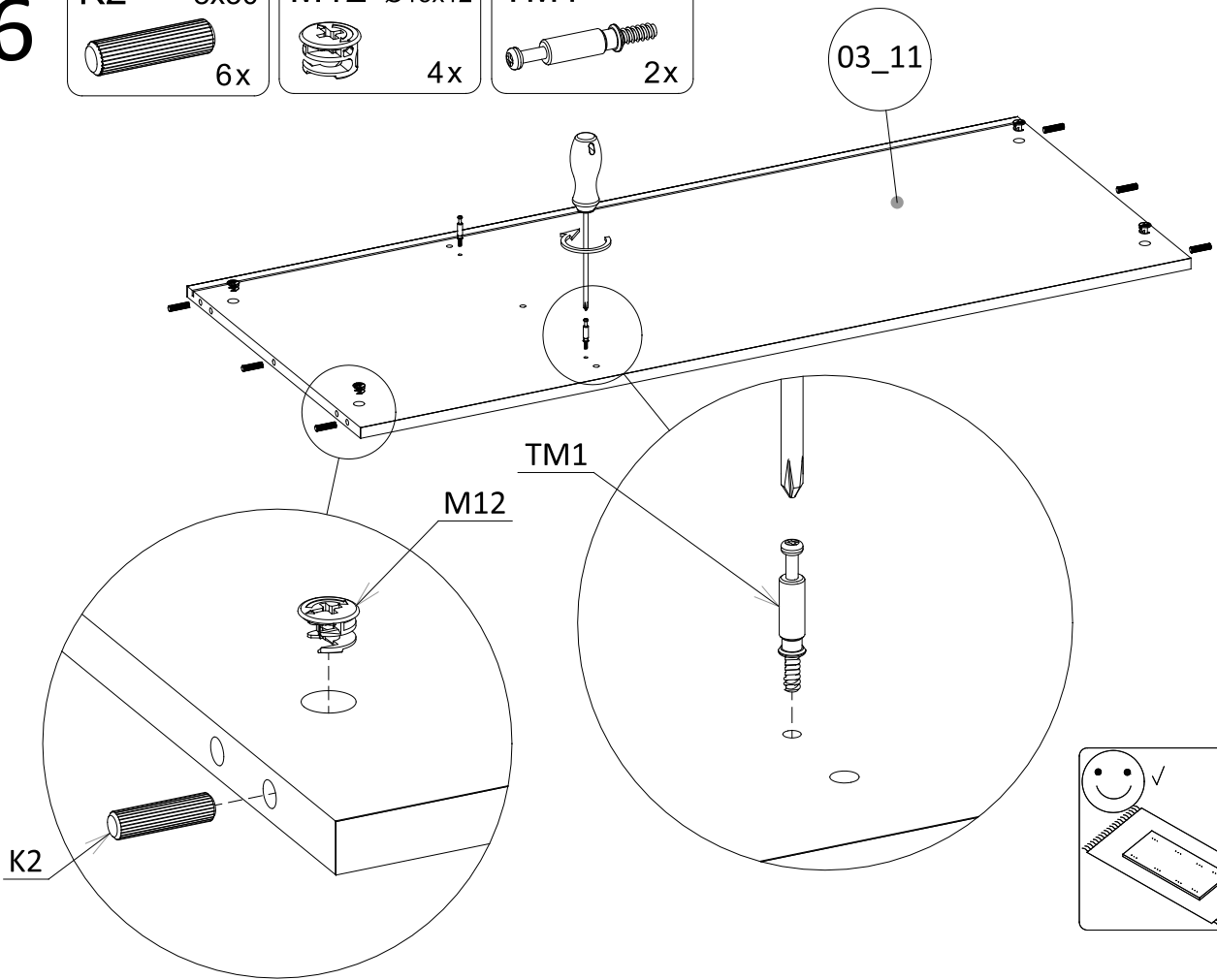
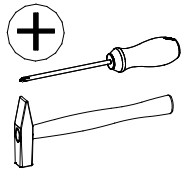

7

NA20 Ø20
042
2x

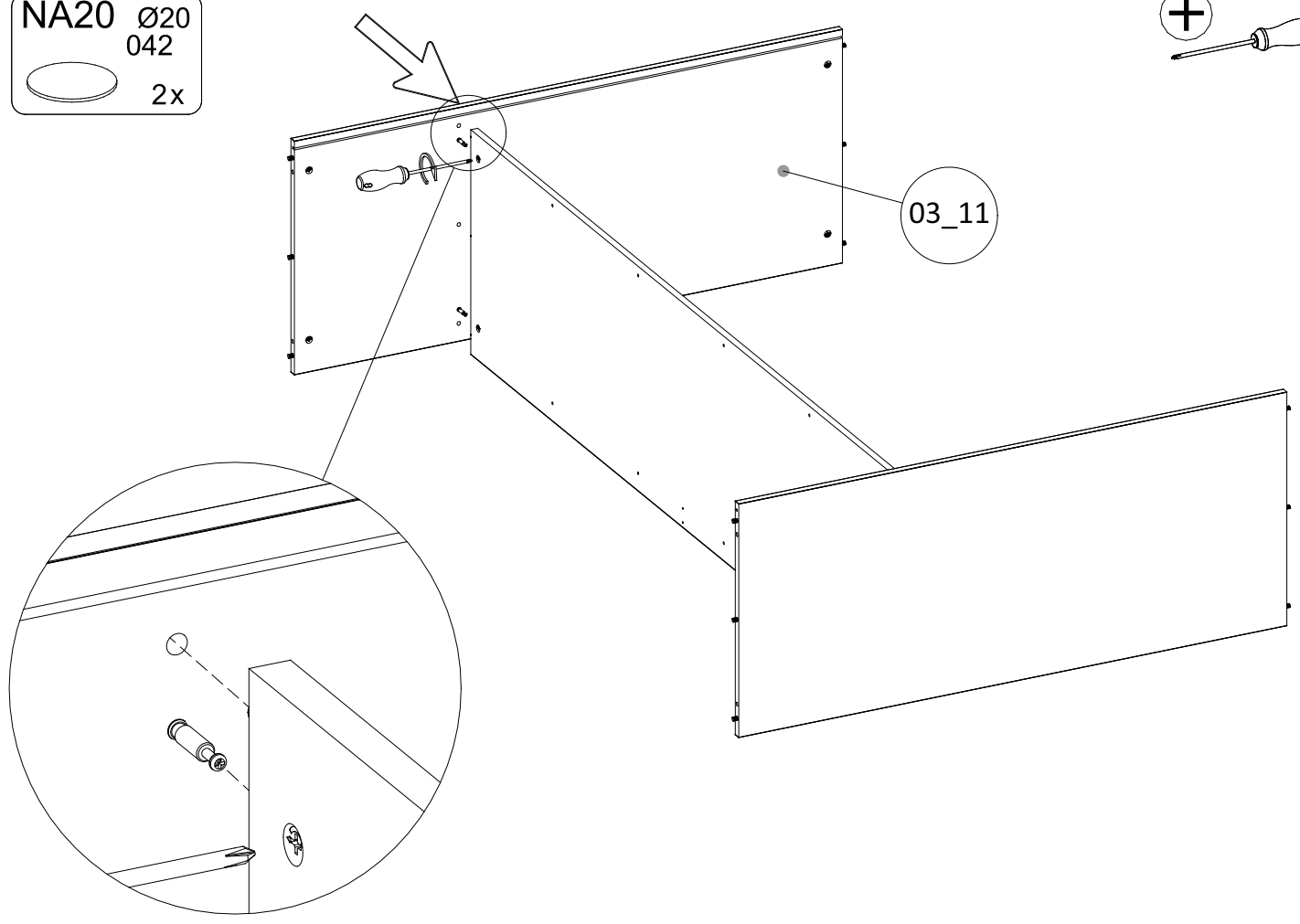
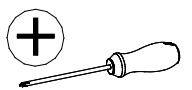

8

K2 8x30
6x

M12 Ø15x12
4x

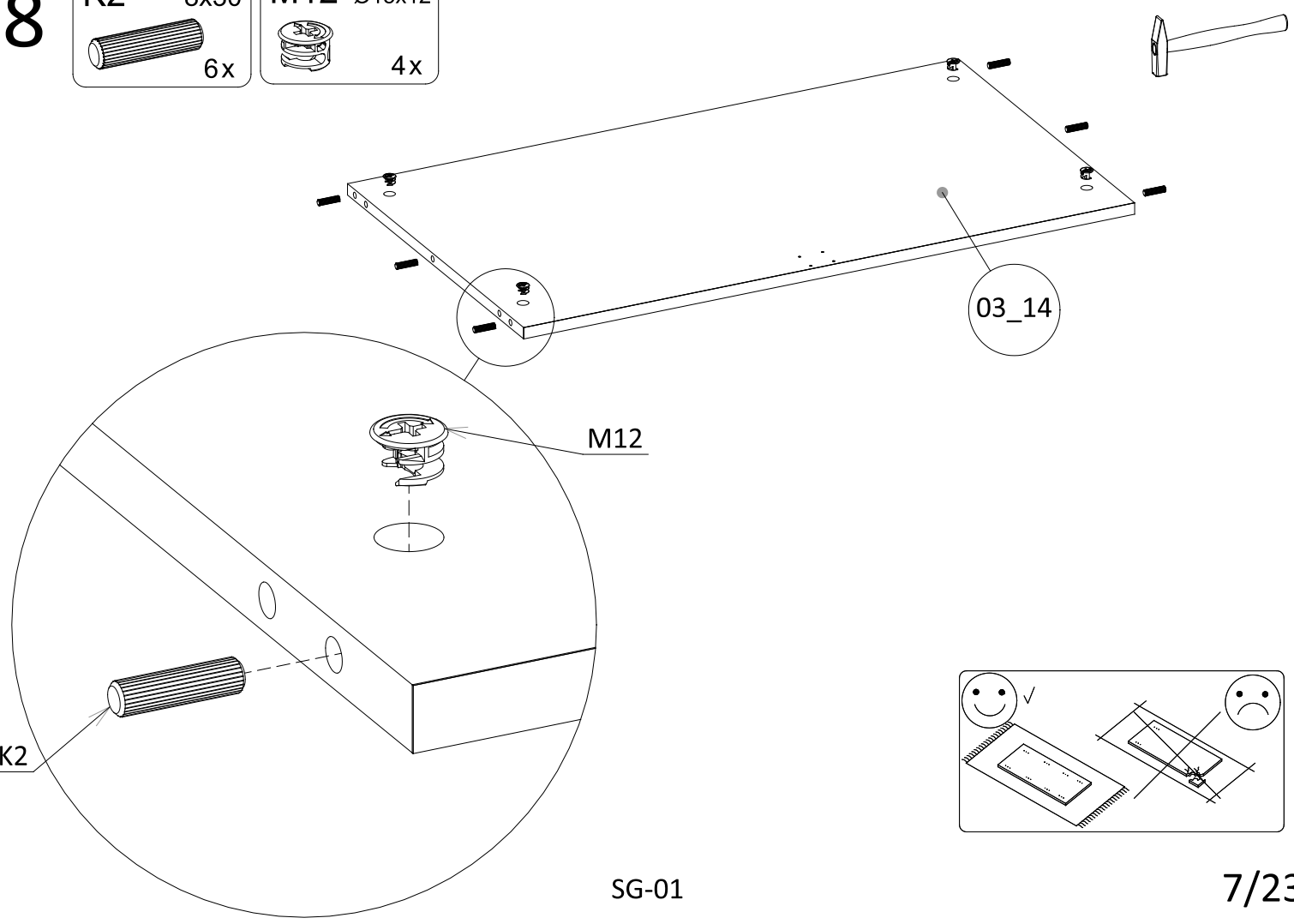

9

NA20 Ø20
042
2x

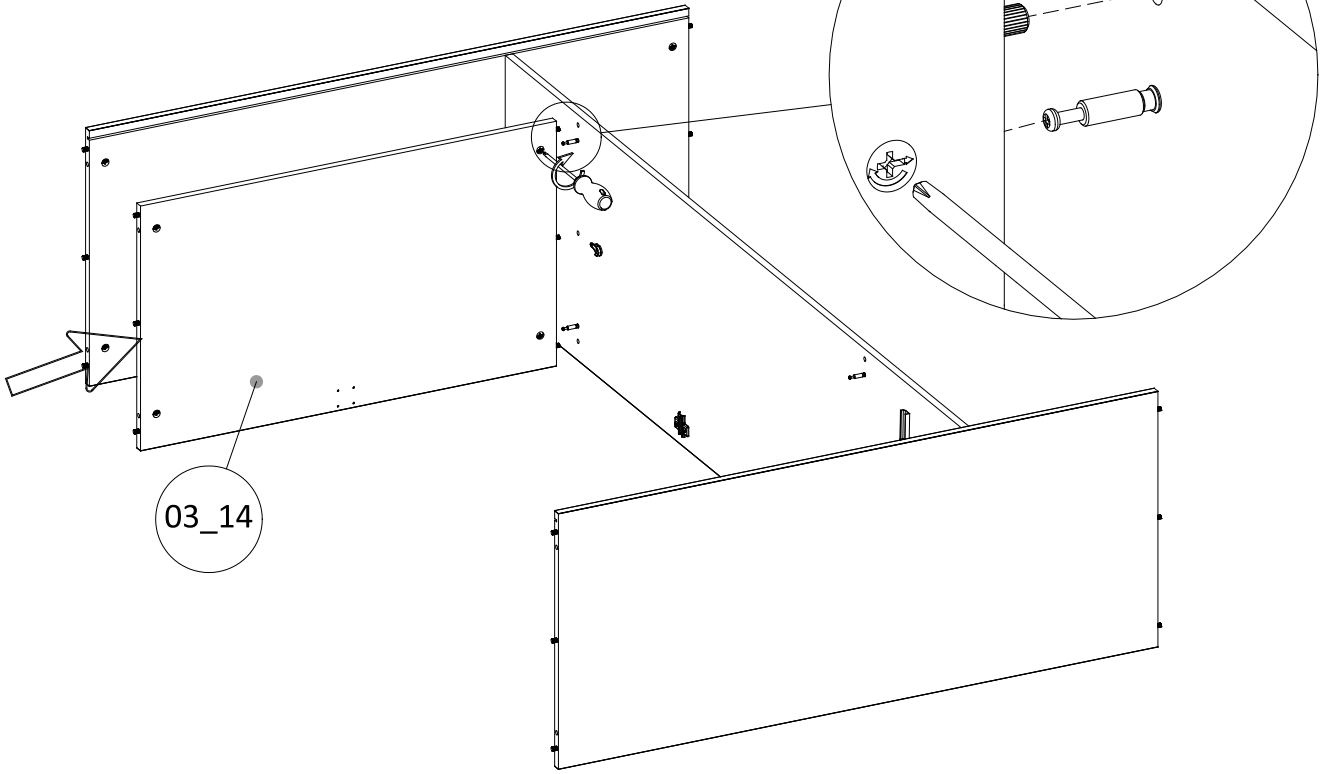
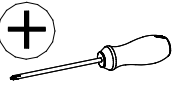

03_14

10

K2 8x30 6x
M12 Ø15x12 4x

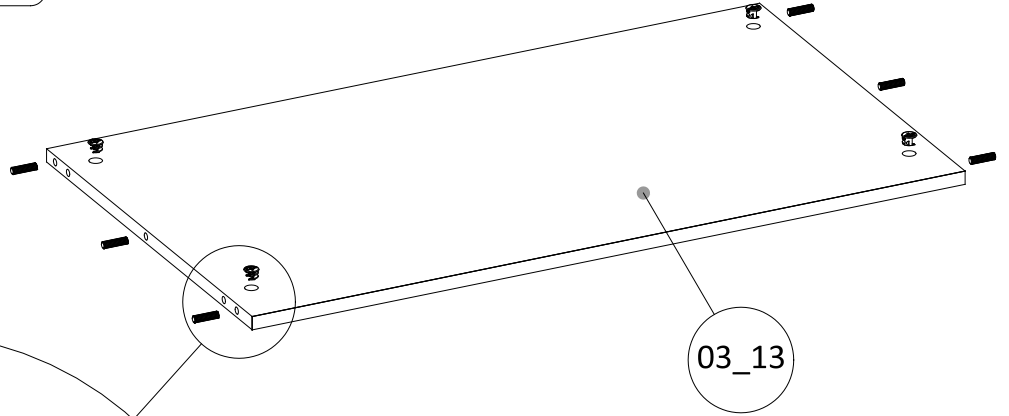

03_13

M12

K2

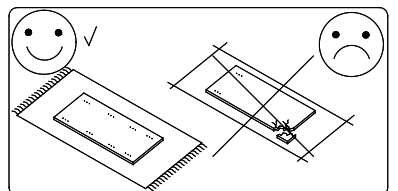
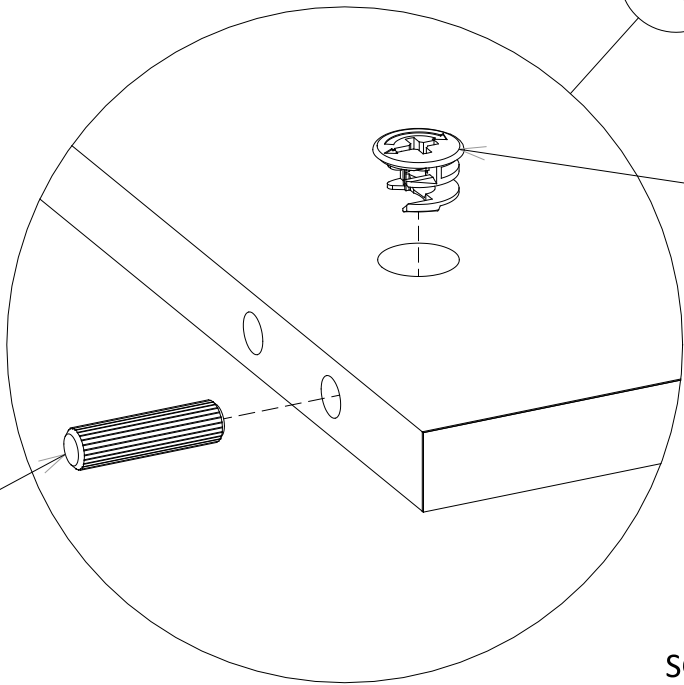

11

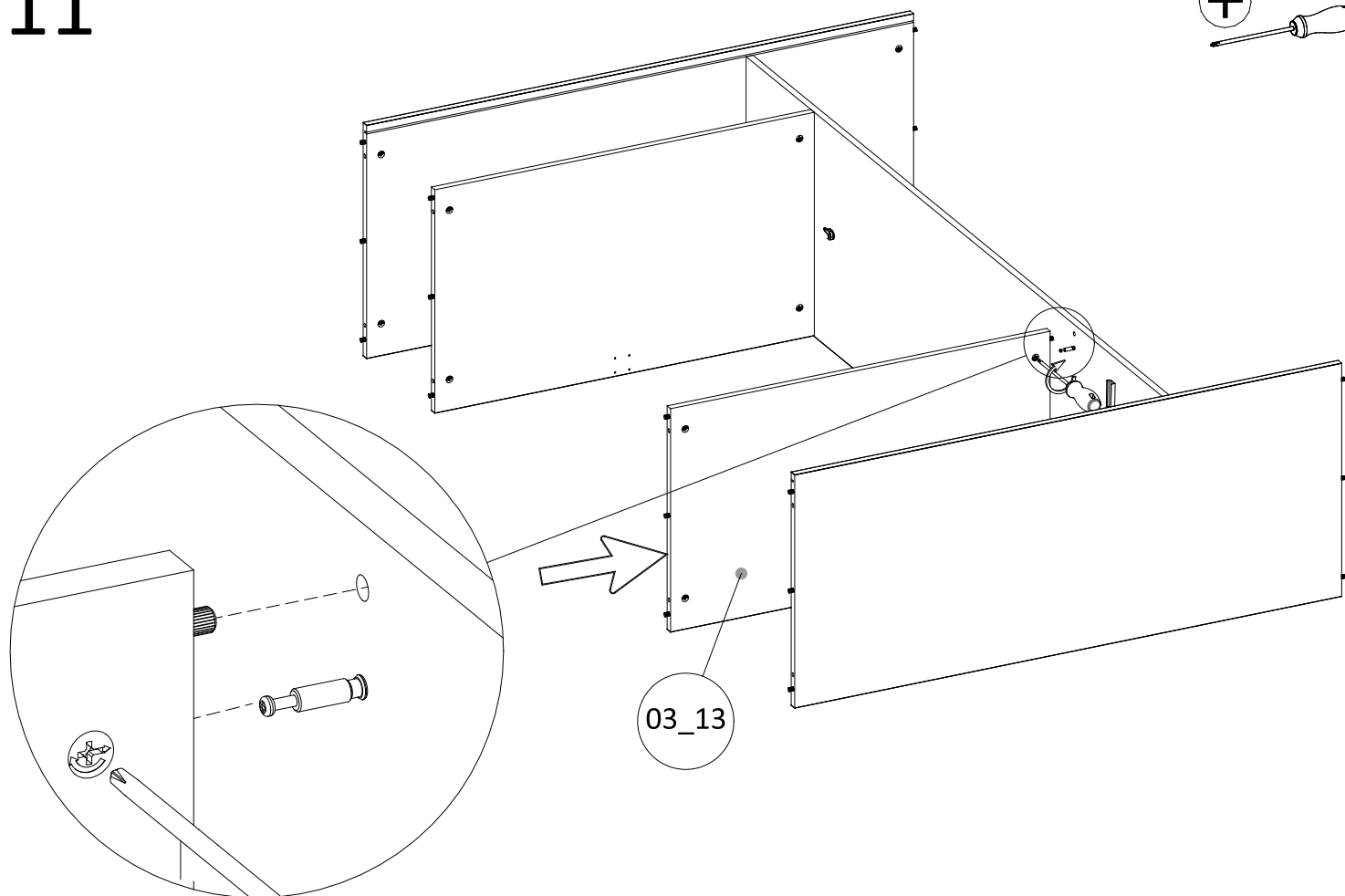
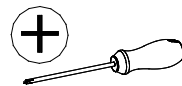

12

- TM1** 8x
- SG** 2x
- H0G** 3x

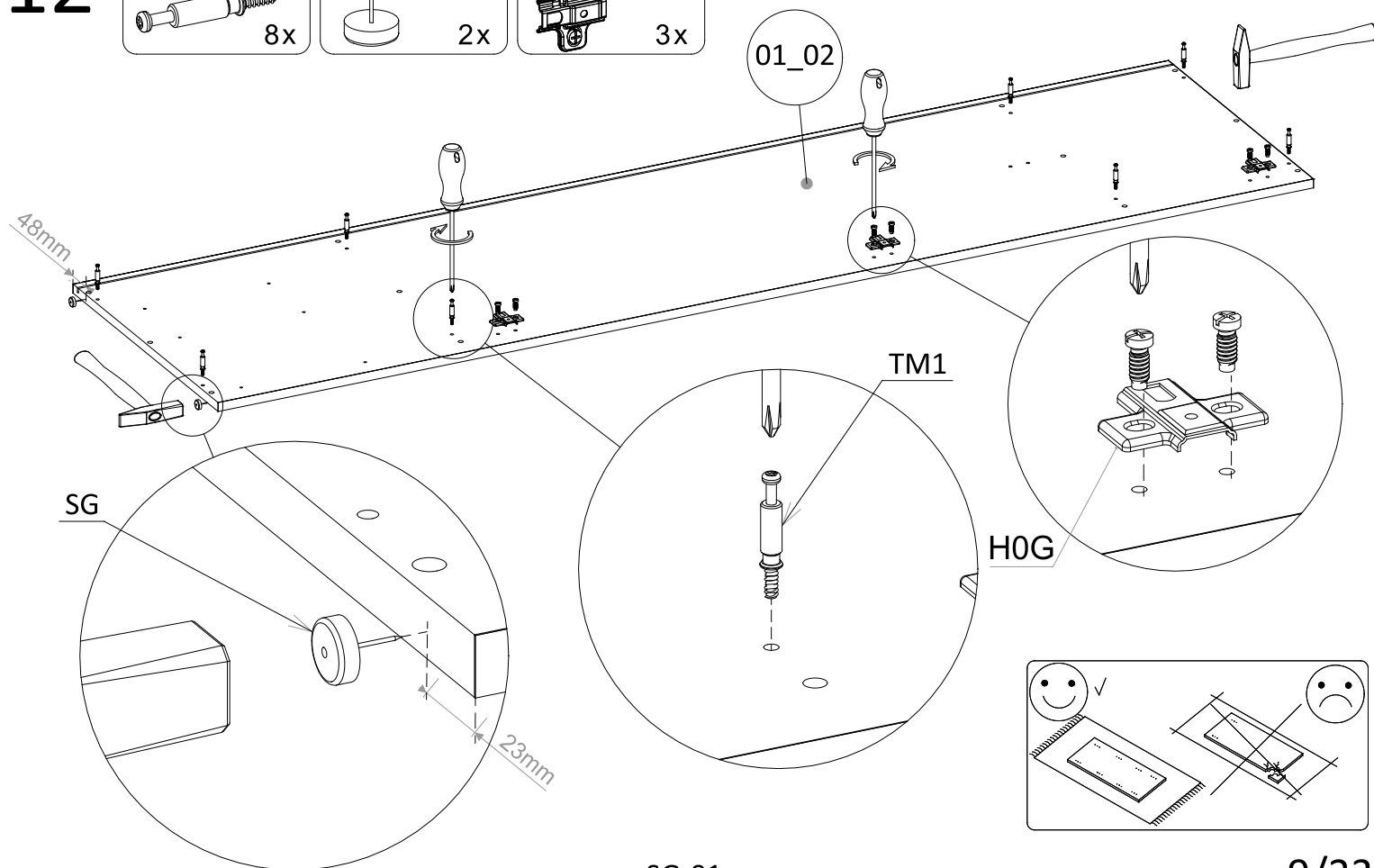
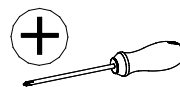

SG-01

9/23

13

PR5 L=450
2x



WDS
1x



W7 4x13
1x

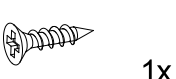

WE61 5x13
6x

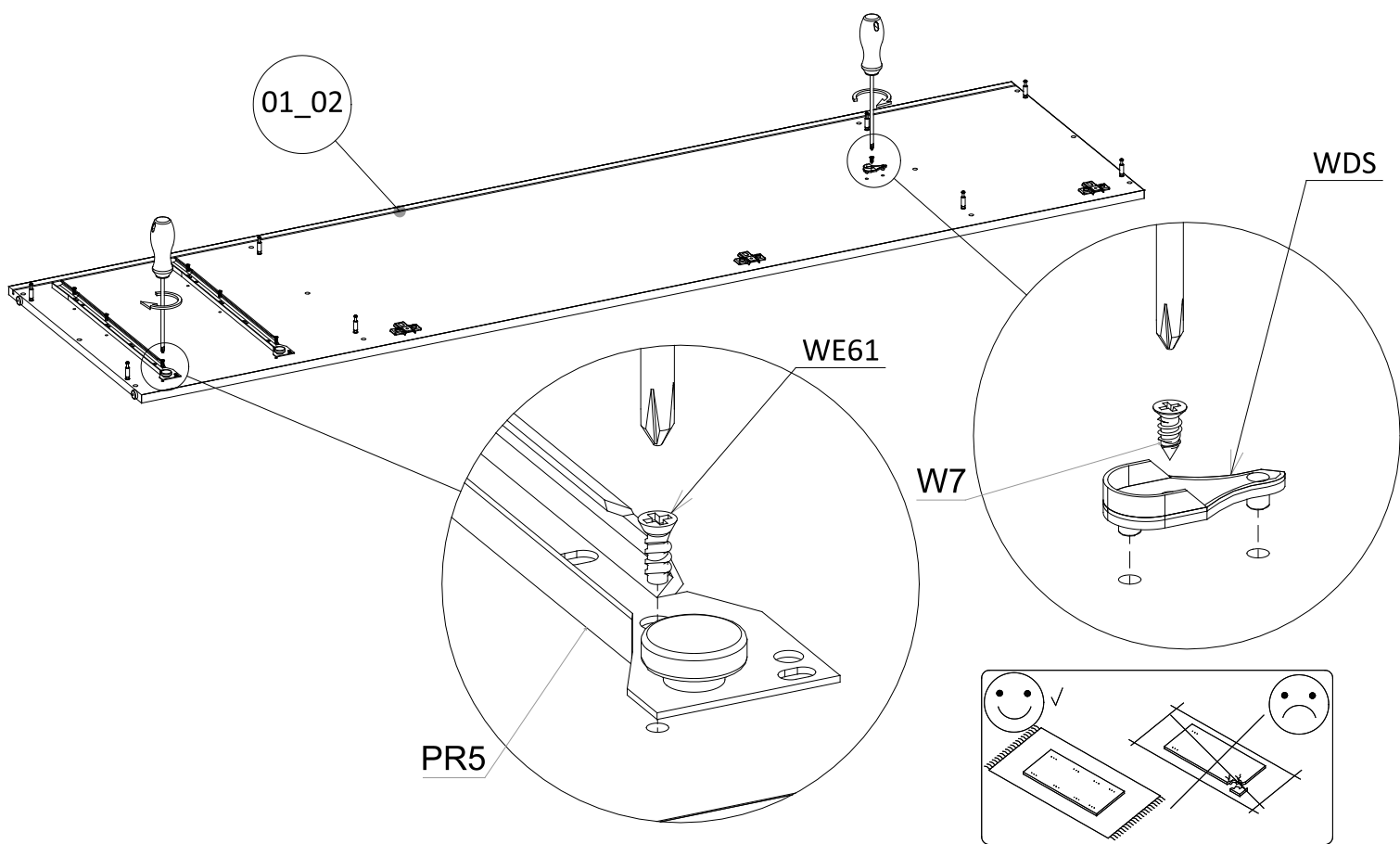
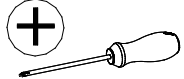

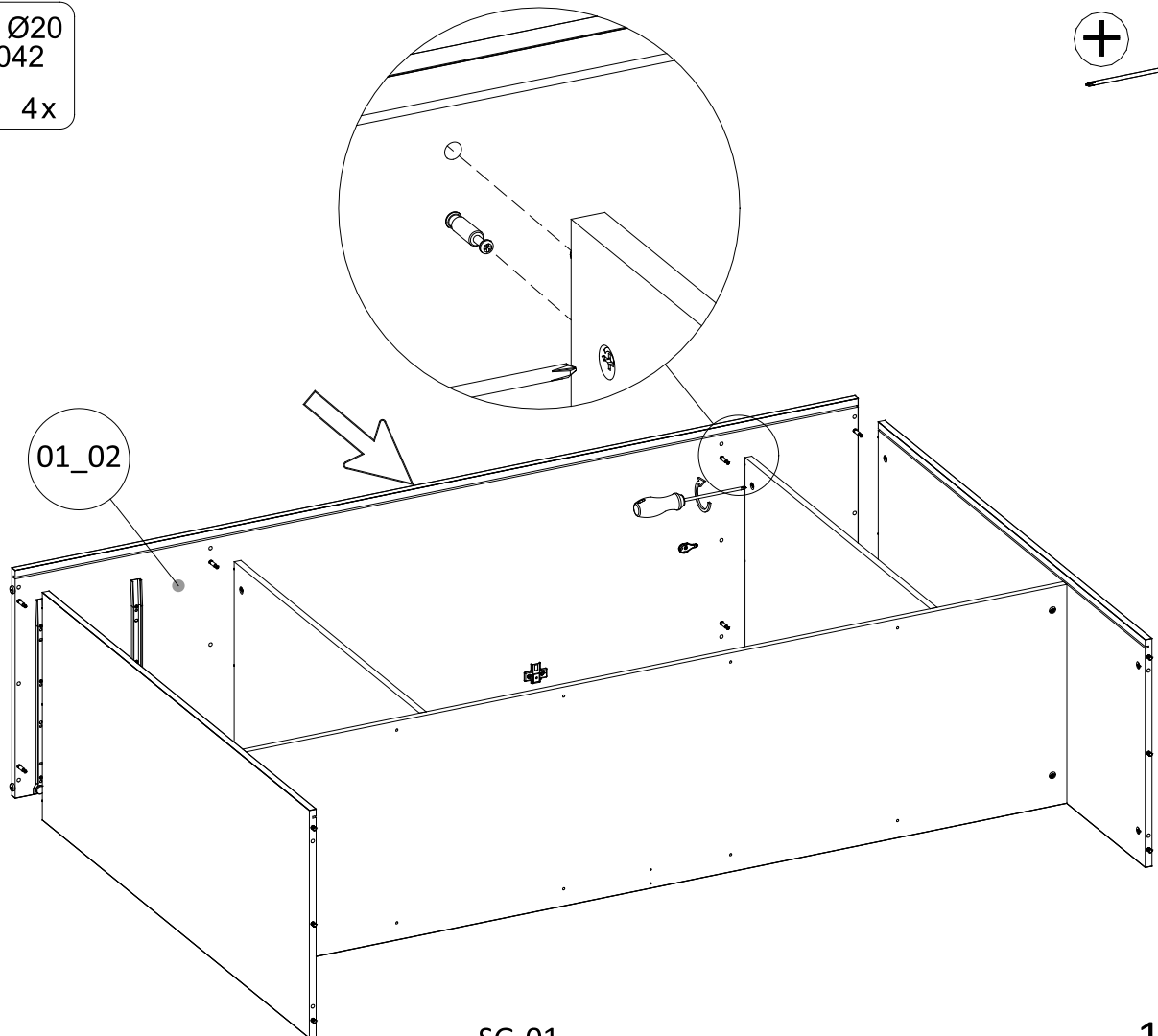
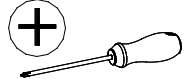

14

NA20 Ø20
042
4x

15 $H_L=1962\text{mm}$
1x

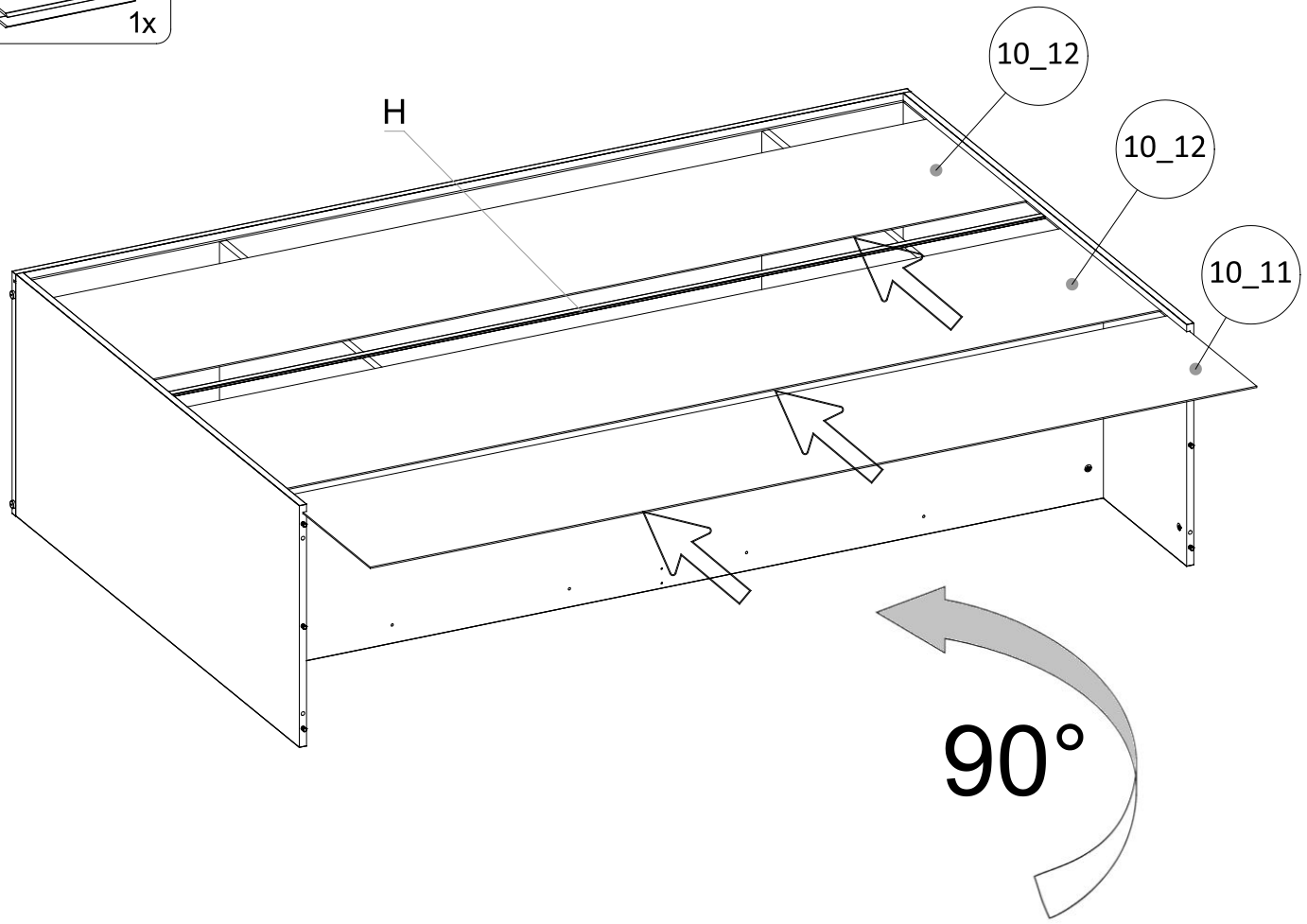

16

TM1 4x	PP6 Ø5 8x	SG 2x	H0G 4x
-----------	--------------	----------	-----------

+

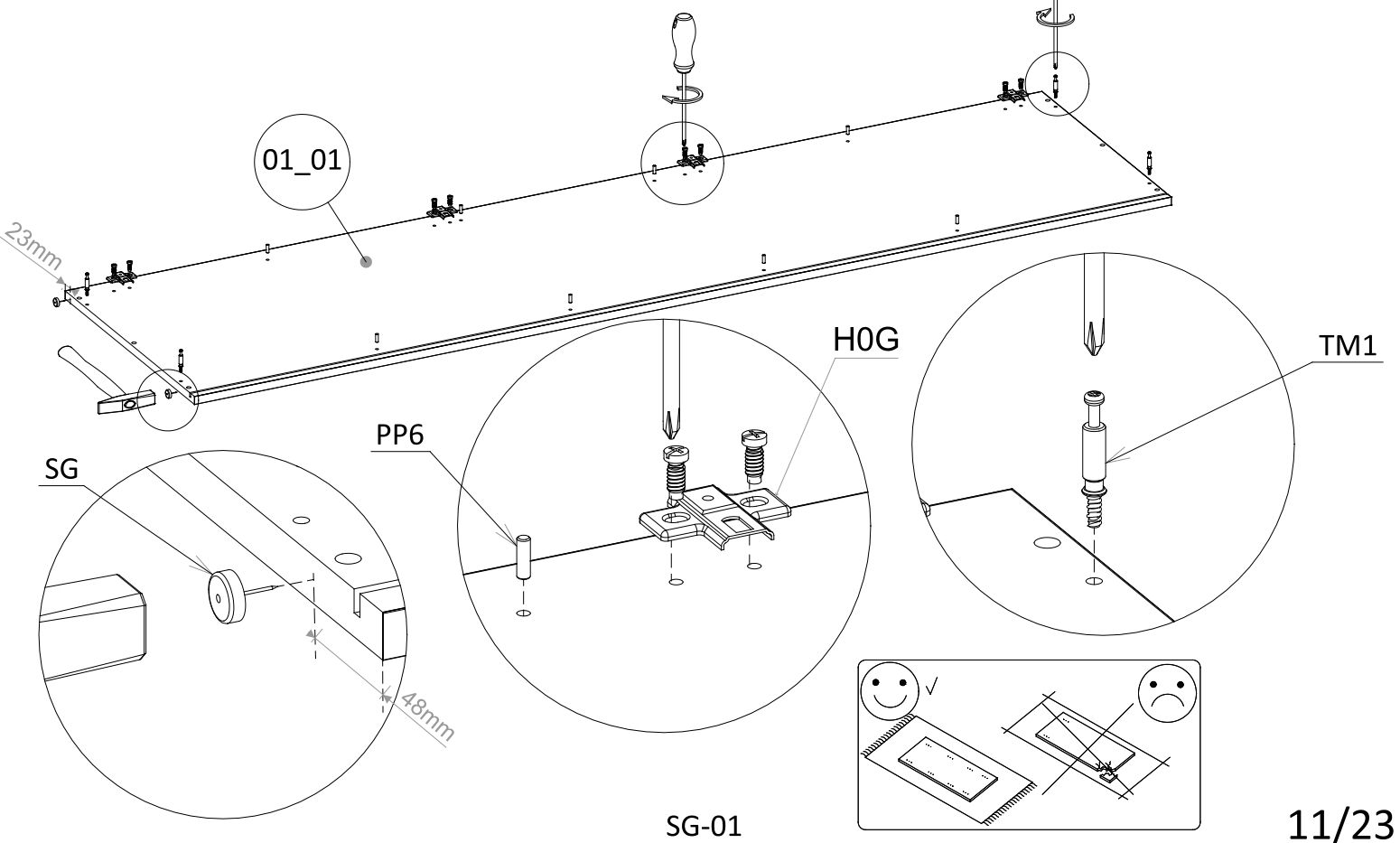

SG-01

17

NA20 Ø20
042
4x

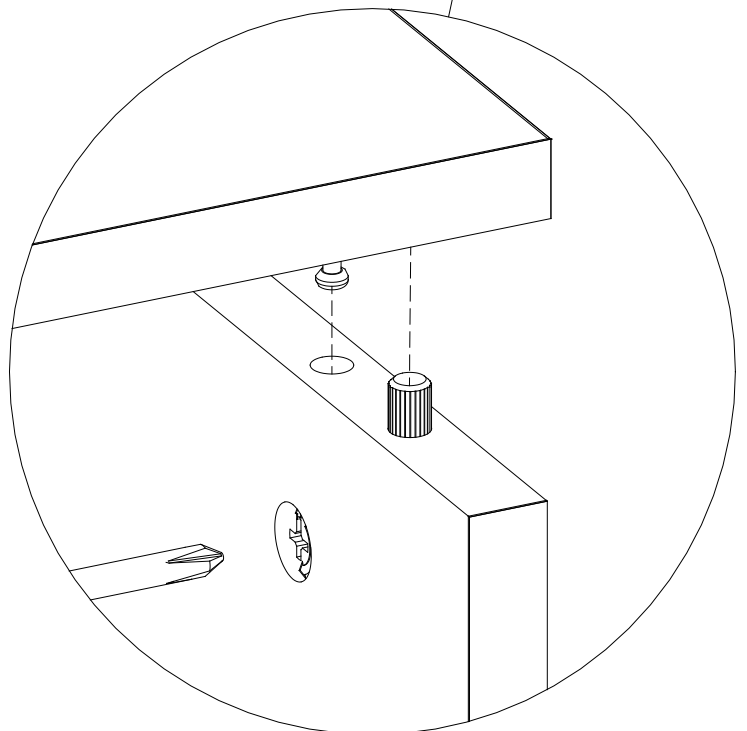
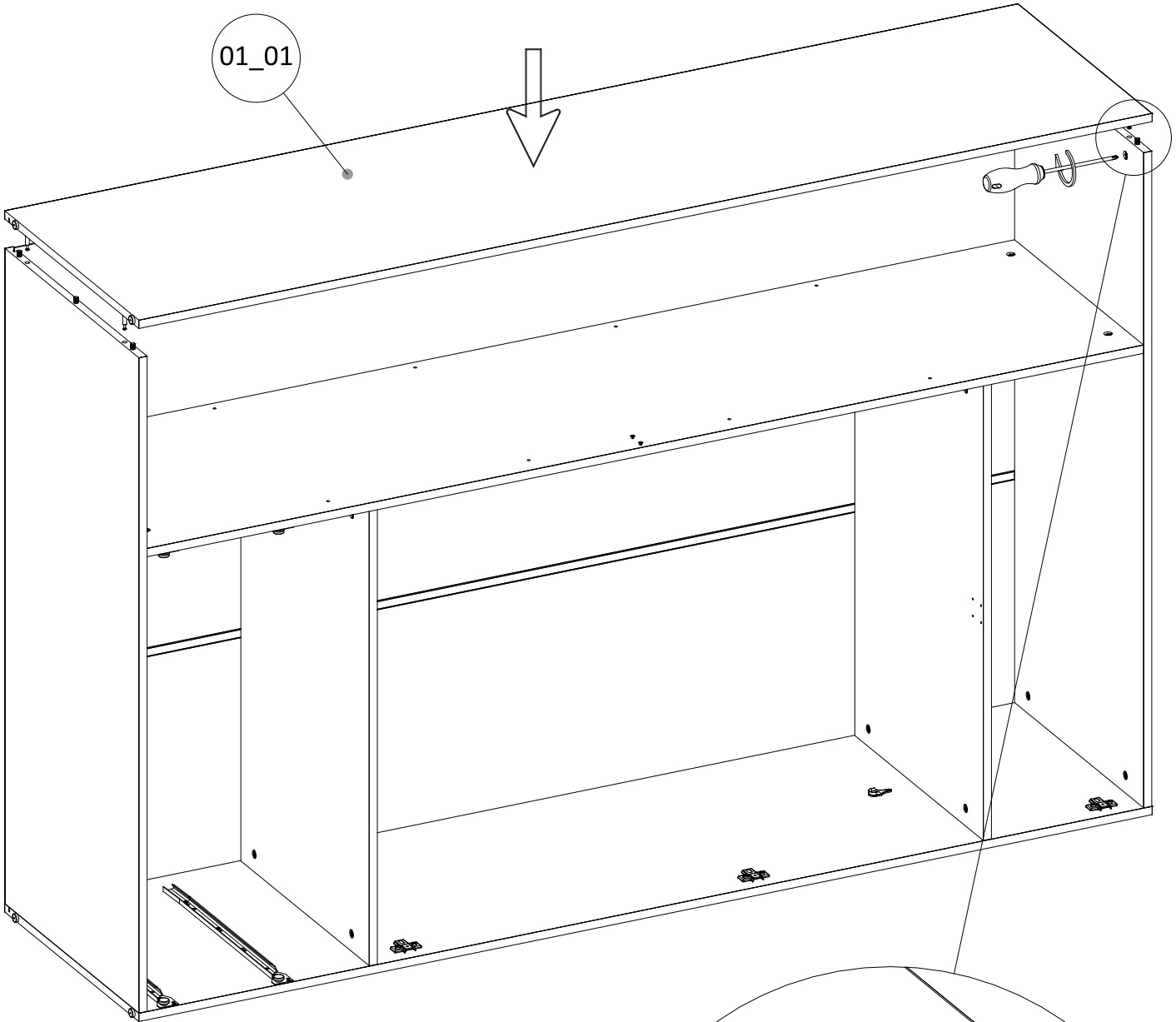
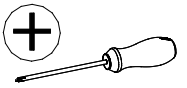

18

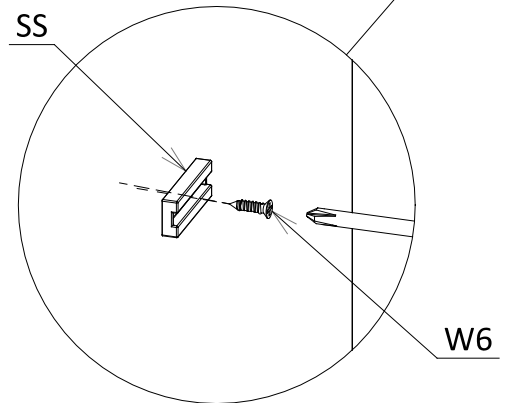
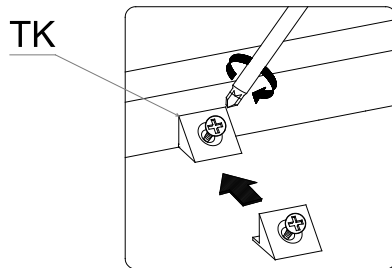
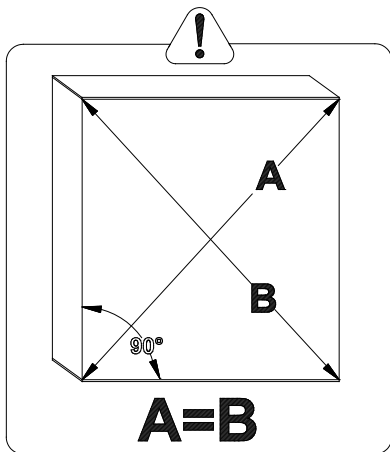
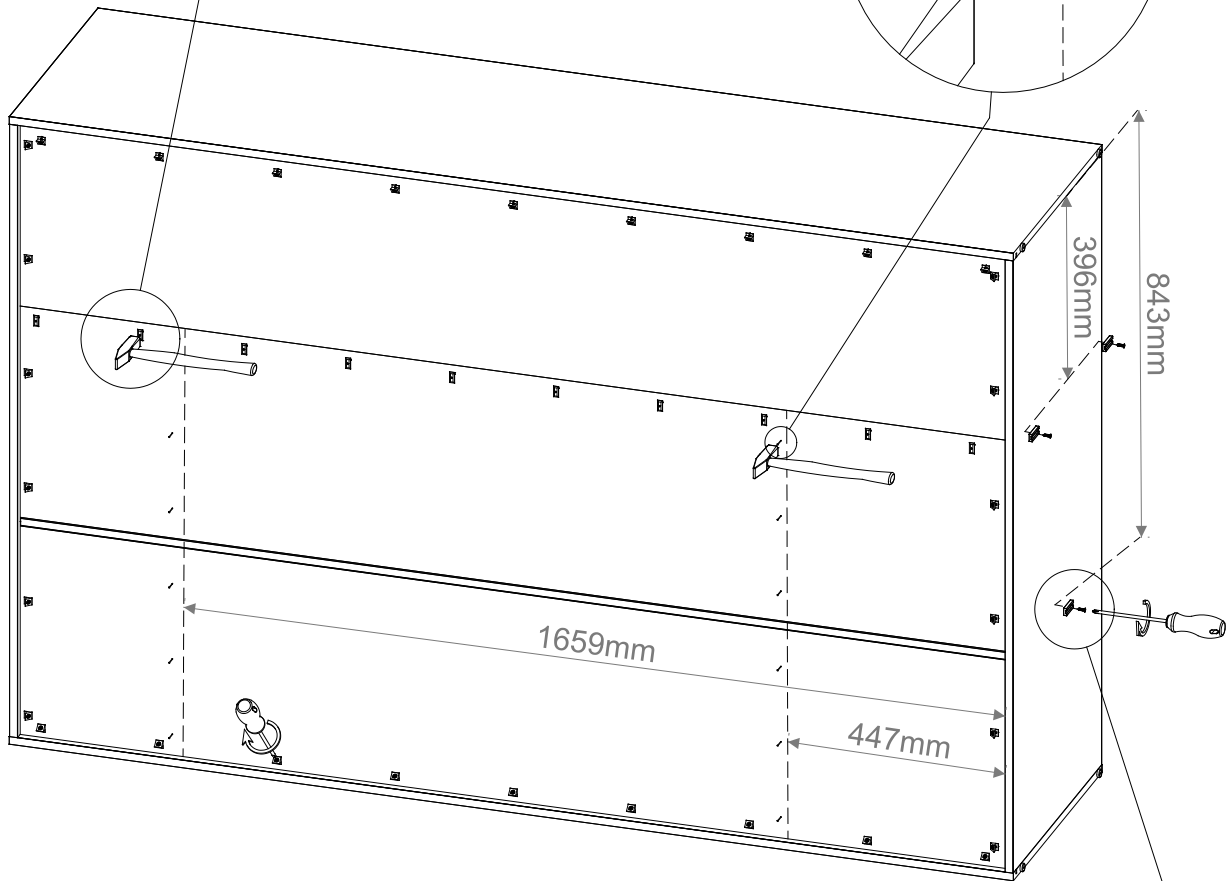
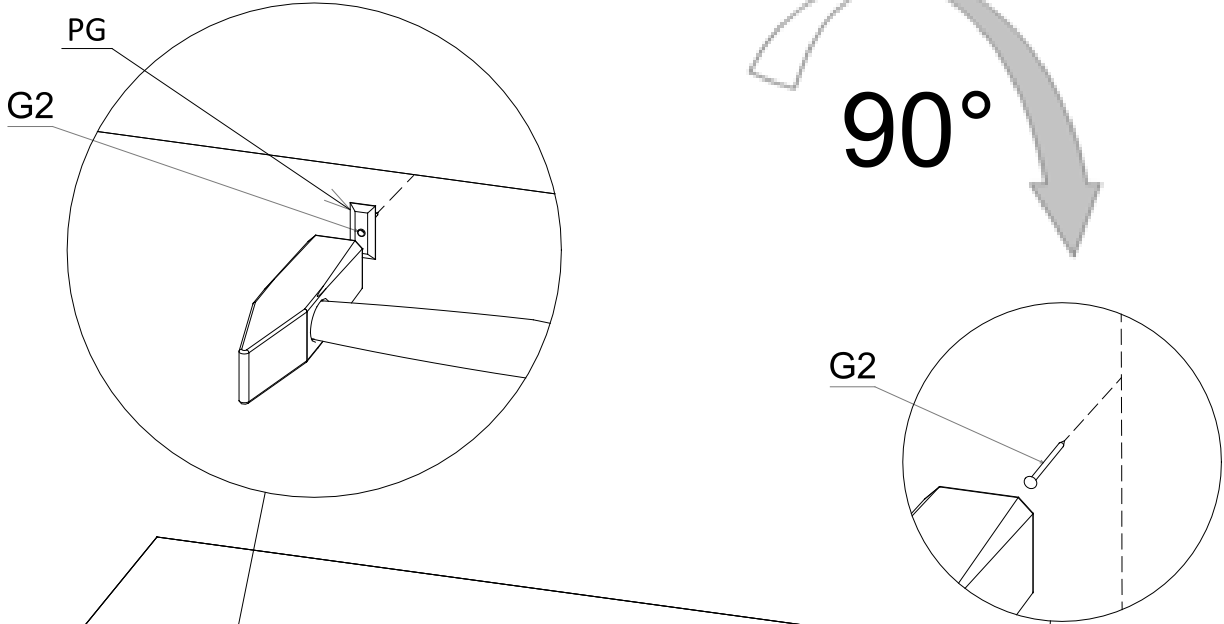
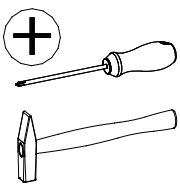
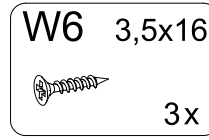
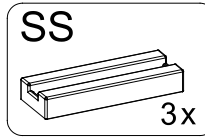
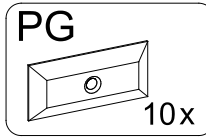
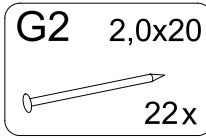
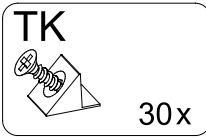

19

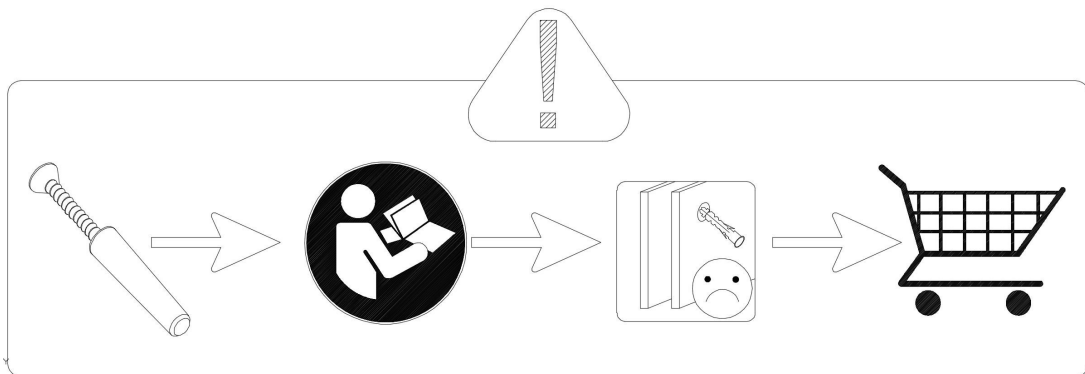
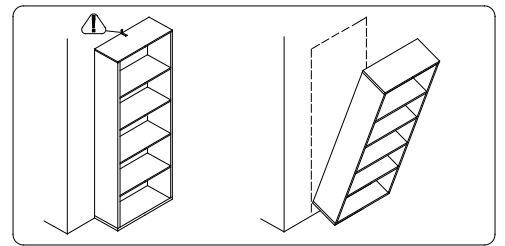
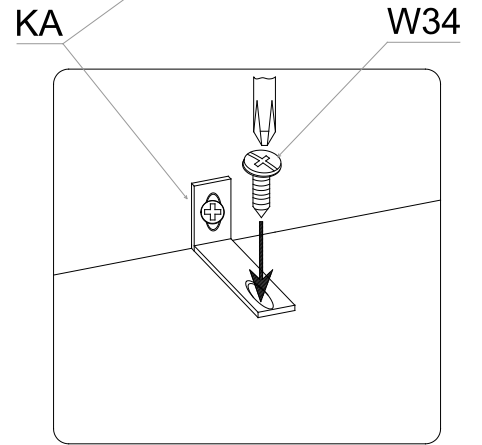
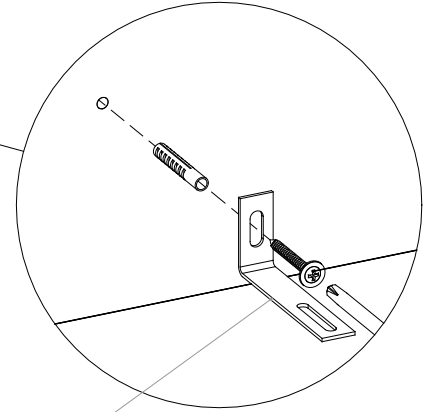
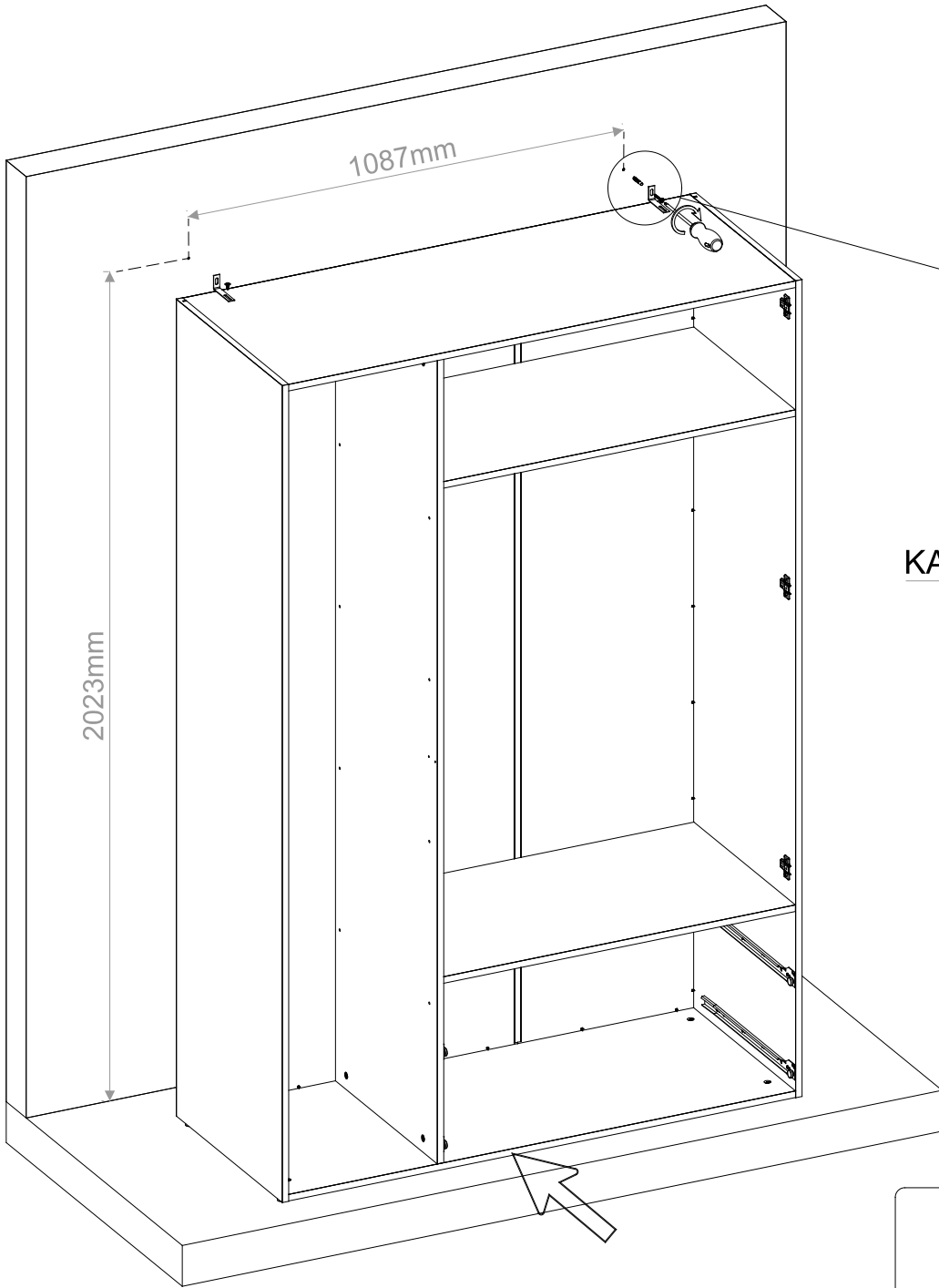
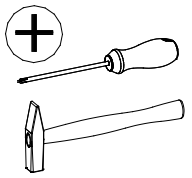
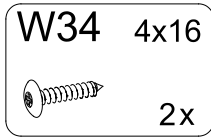
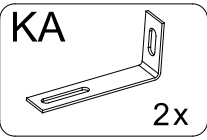

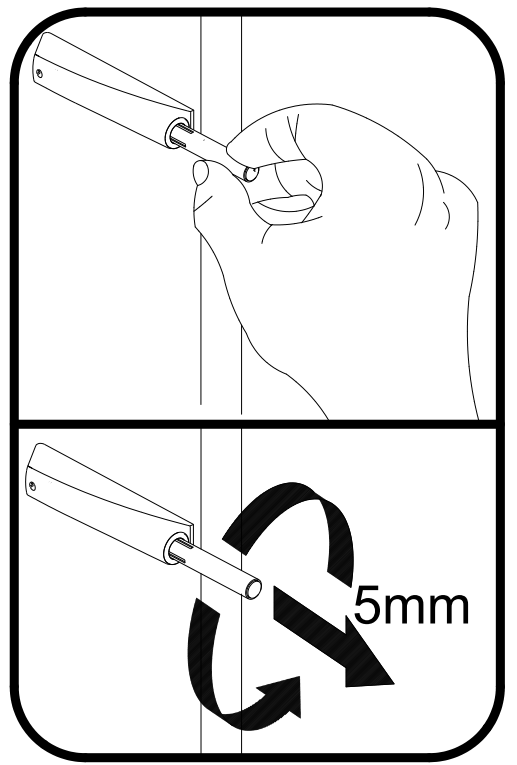
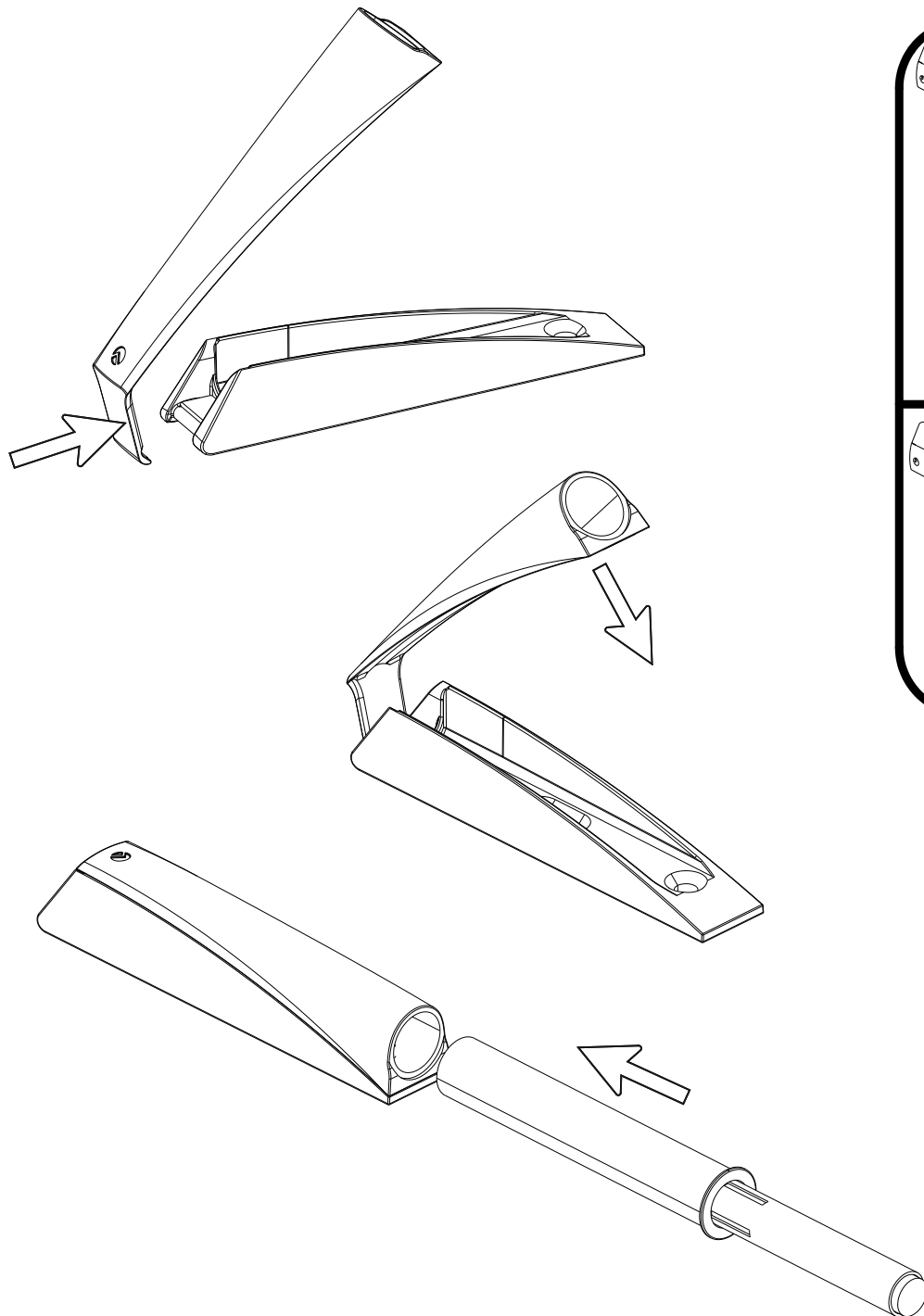
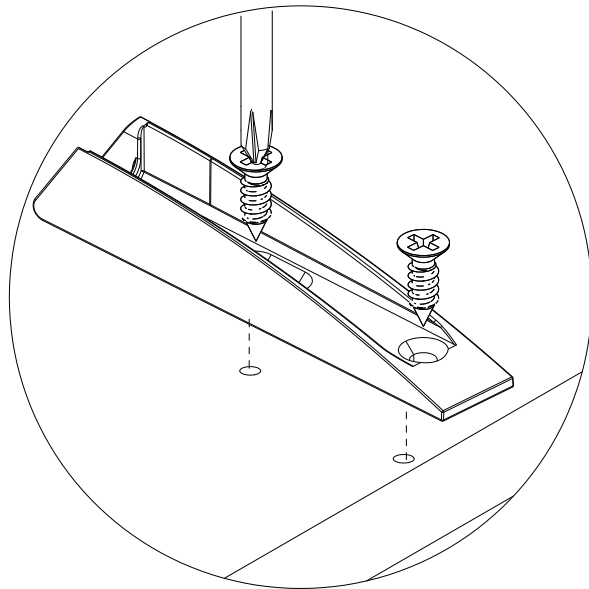

20

- PP6 Ø5 8x
- OIF 1/3 2/3 3/3 3x
- K-02
- W3 3x13 6x

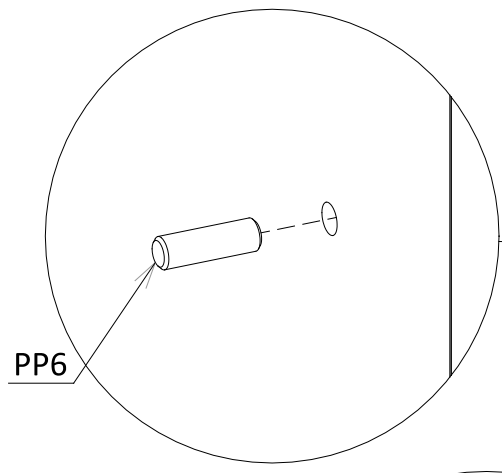
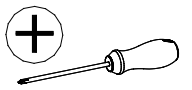

PP6

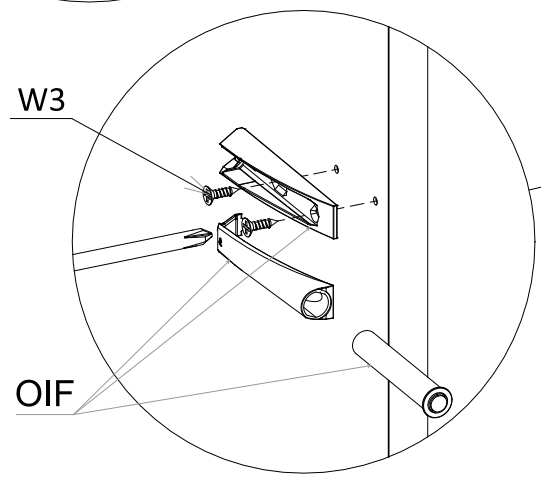

W3

OIF

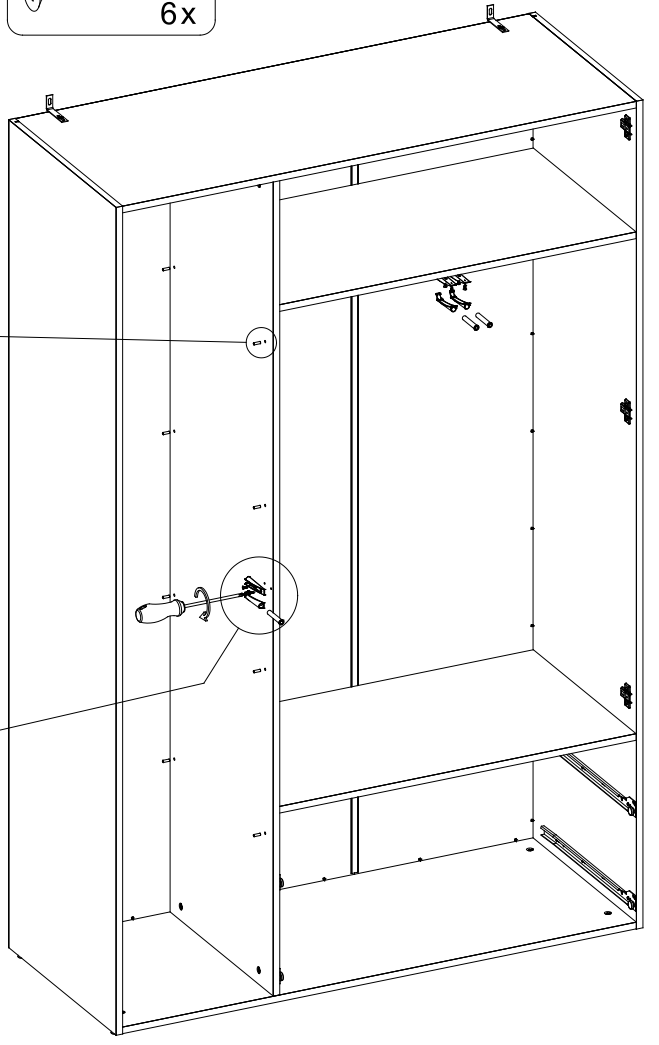

21

- DH L=871 mm 1x

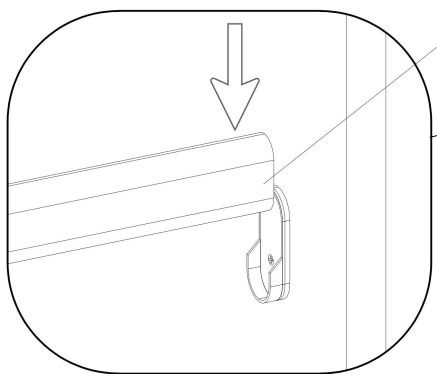

DH

05_11

05_11

05_11

05_11

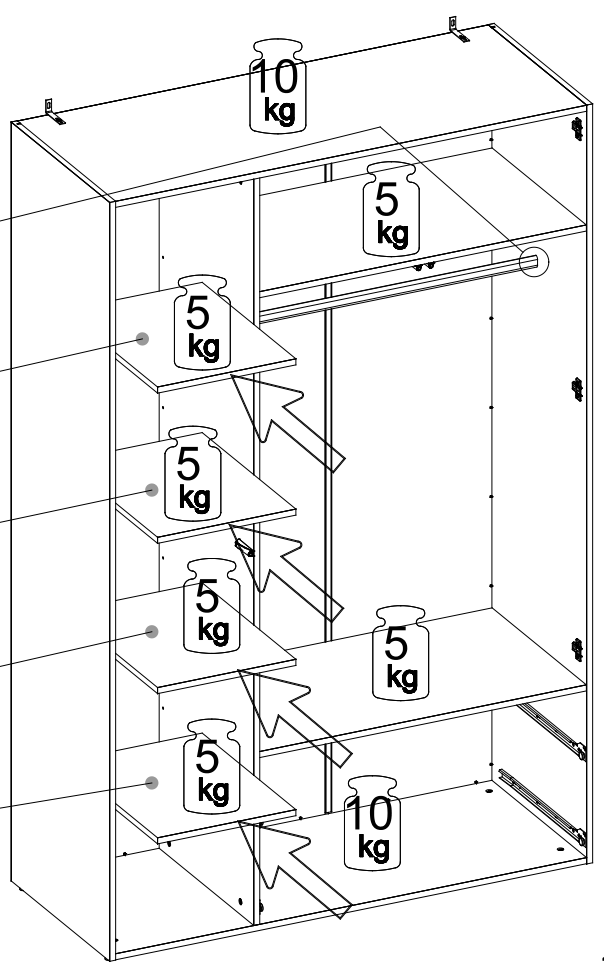

22

K1 6x30
2x4



M10 Ø15x10
2x4



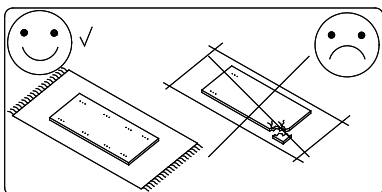
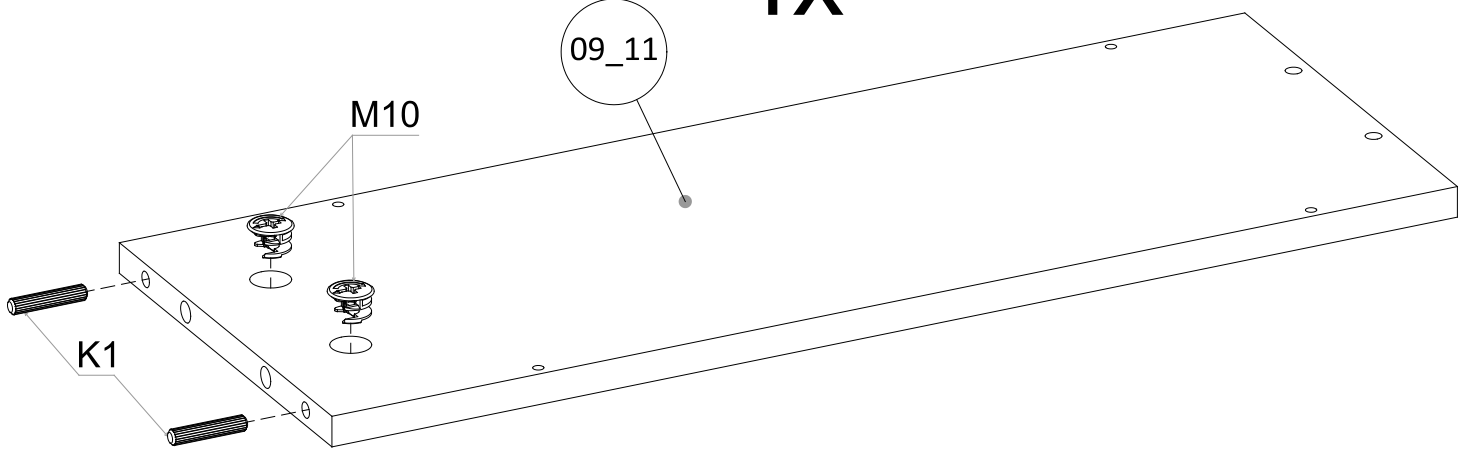

4x

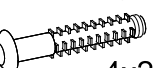

23

KP 6x40
4x2



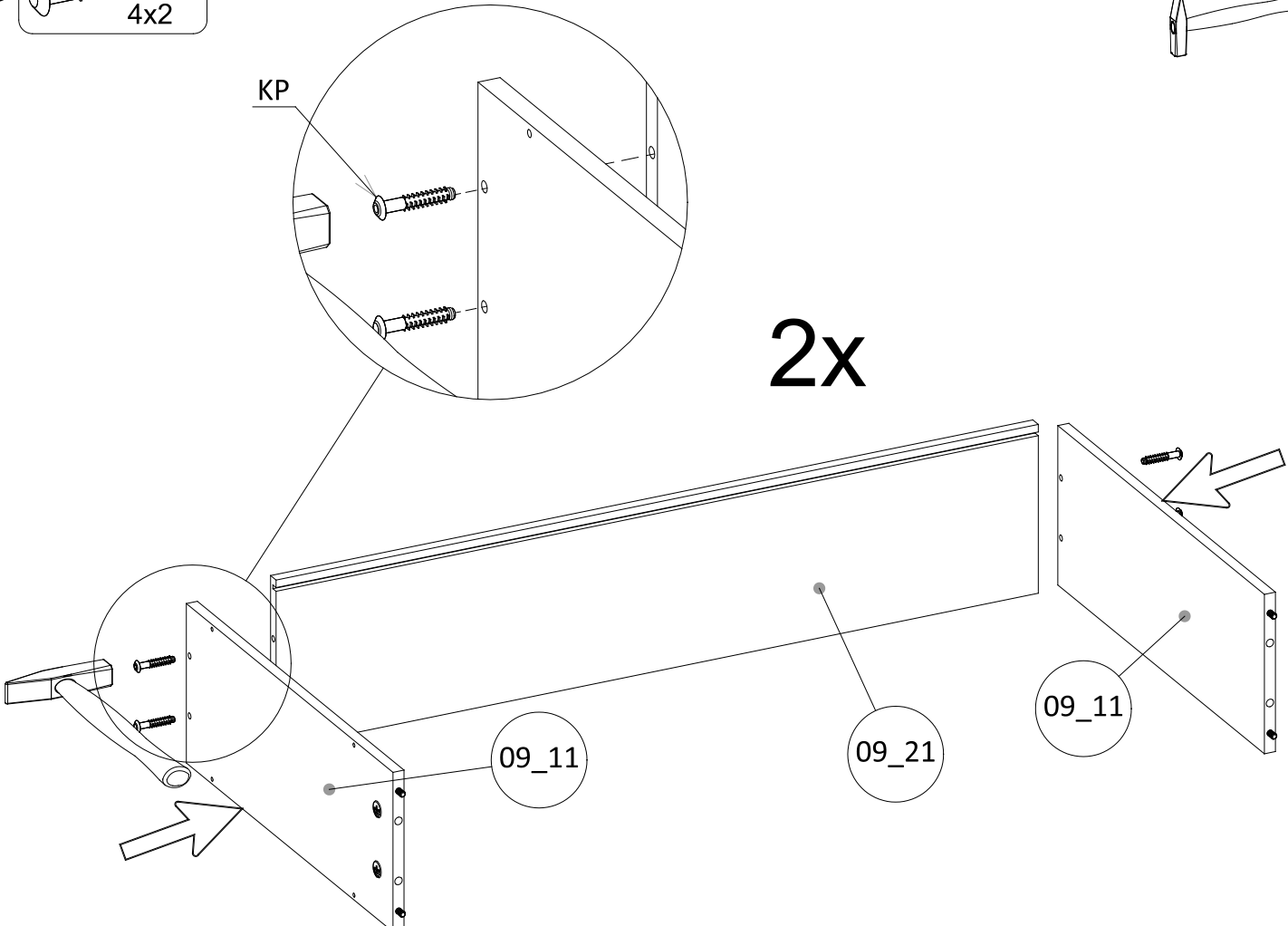

2x

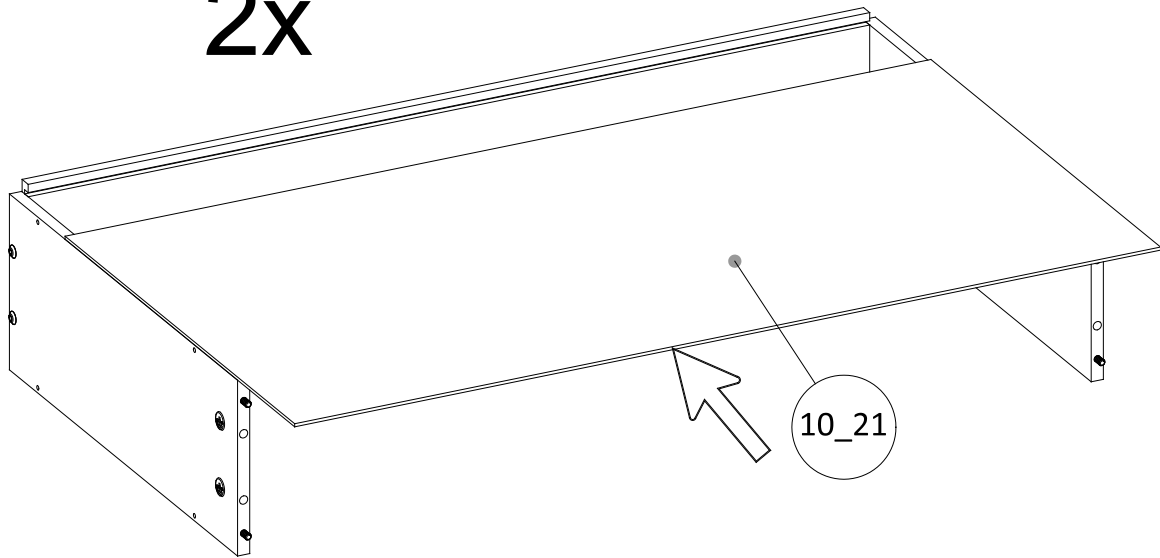

24

2x



25

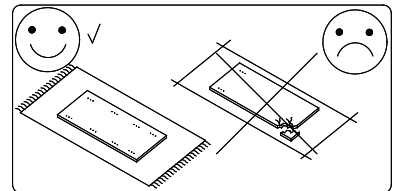
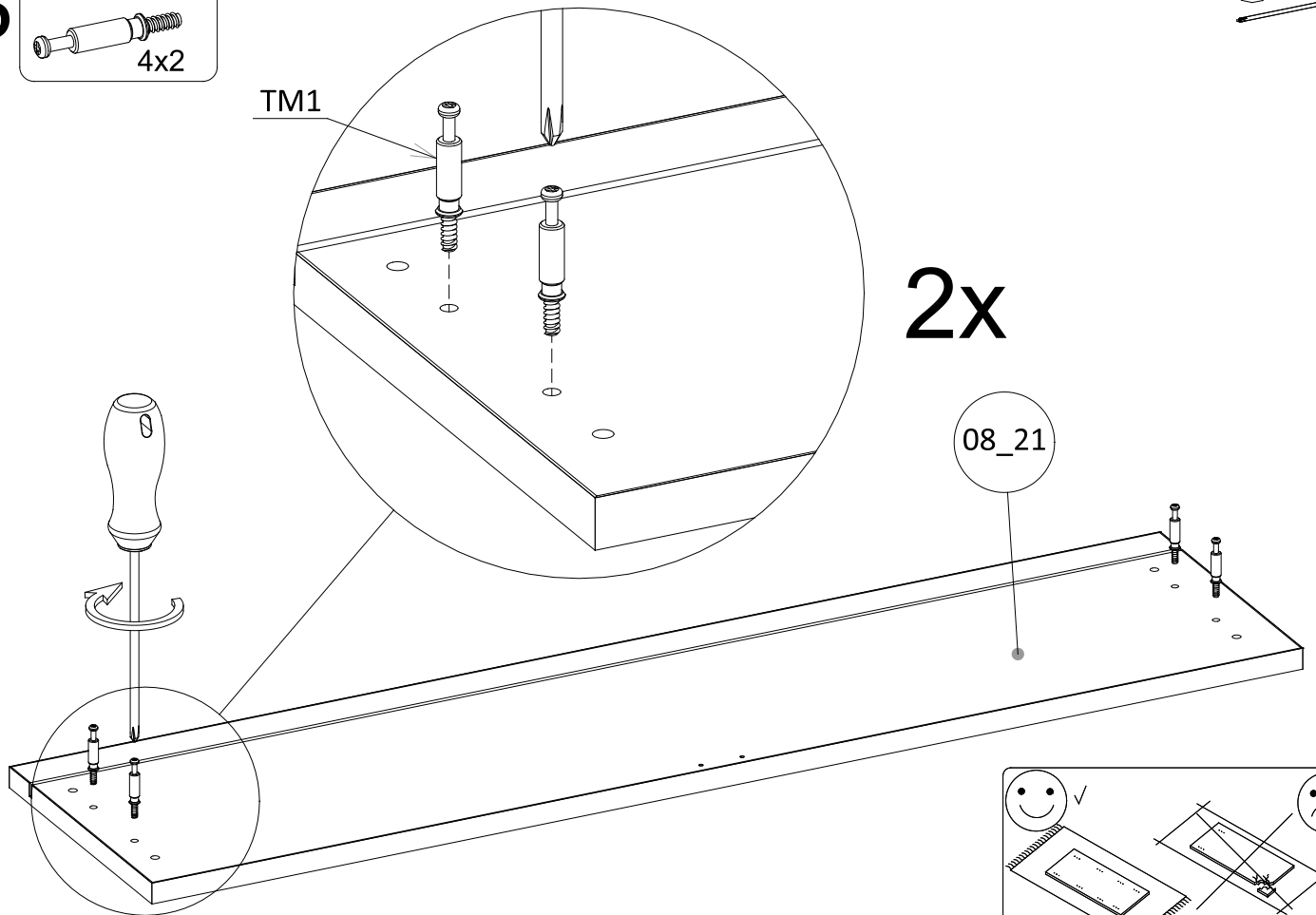
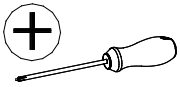
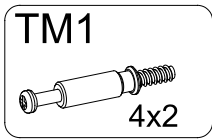

26

ZS10 ϕ 18
K-01
4x2

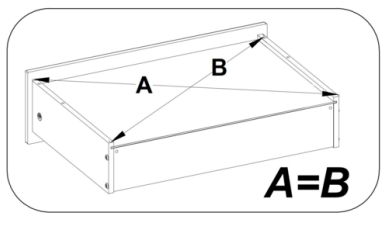
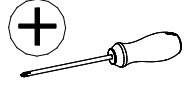
2x

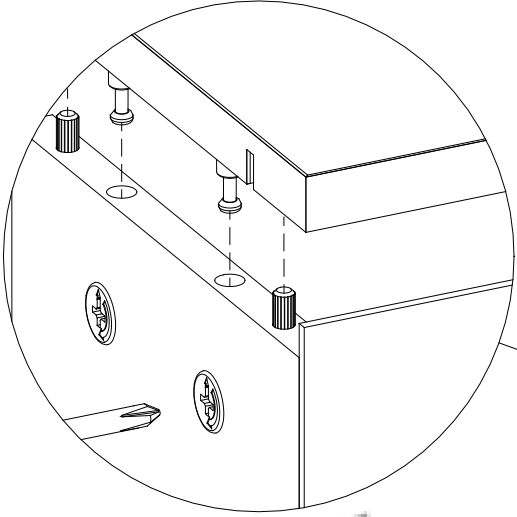

90°

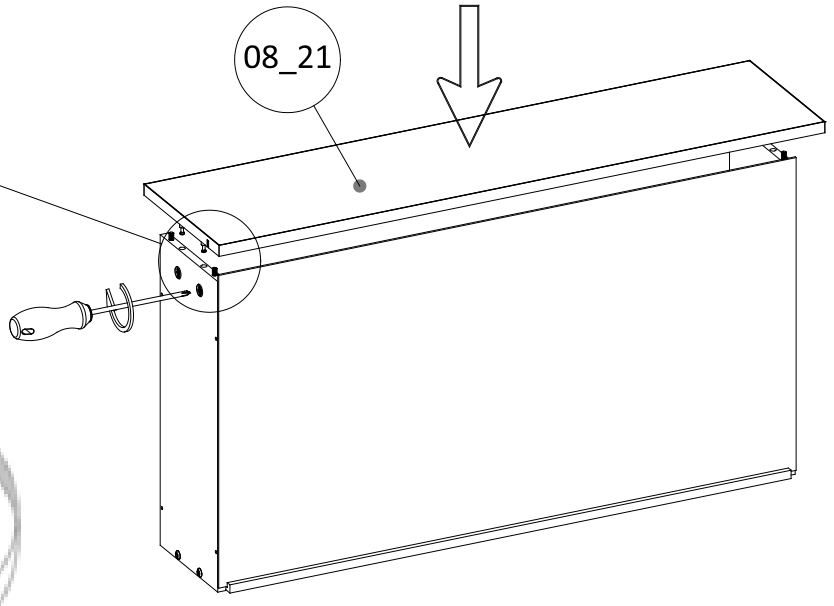

27

PR5 L=450
2x2

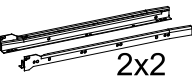

WE66 5x9
4x2



W33 4x13
2x1

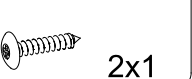

WSL L=450
2x1

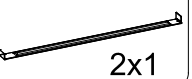

W7 4x13
2x1

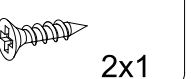
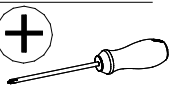

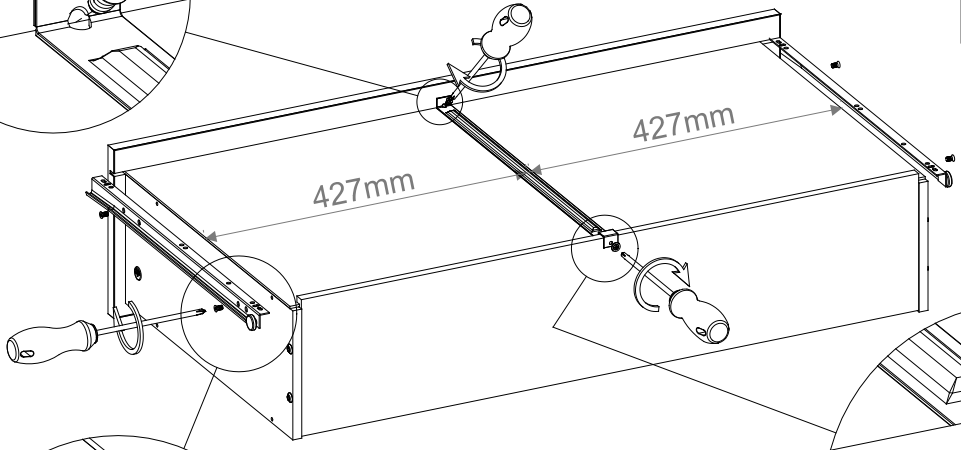
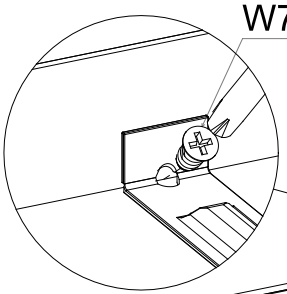

2x

180°

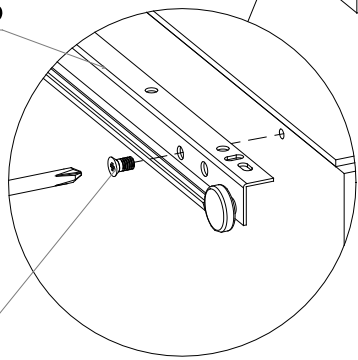

PR5



WSL

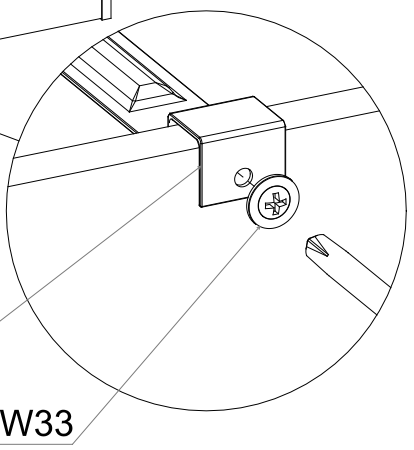

W33

WE66

28

UHR L=45
 1x2

W2 2,5x13
 2x2

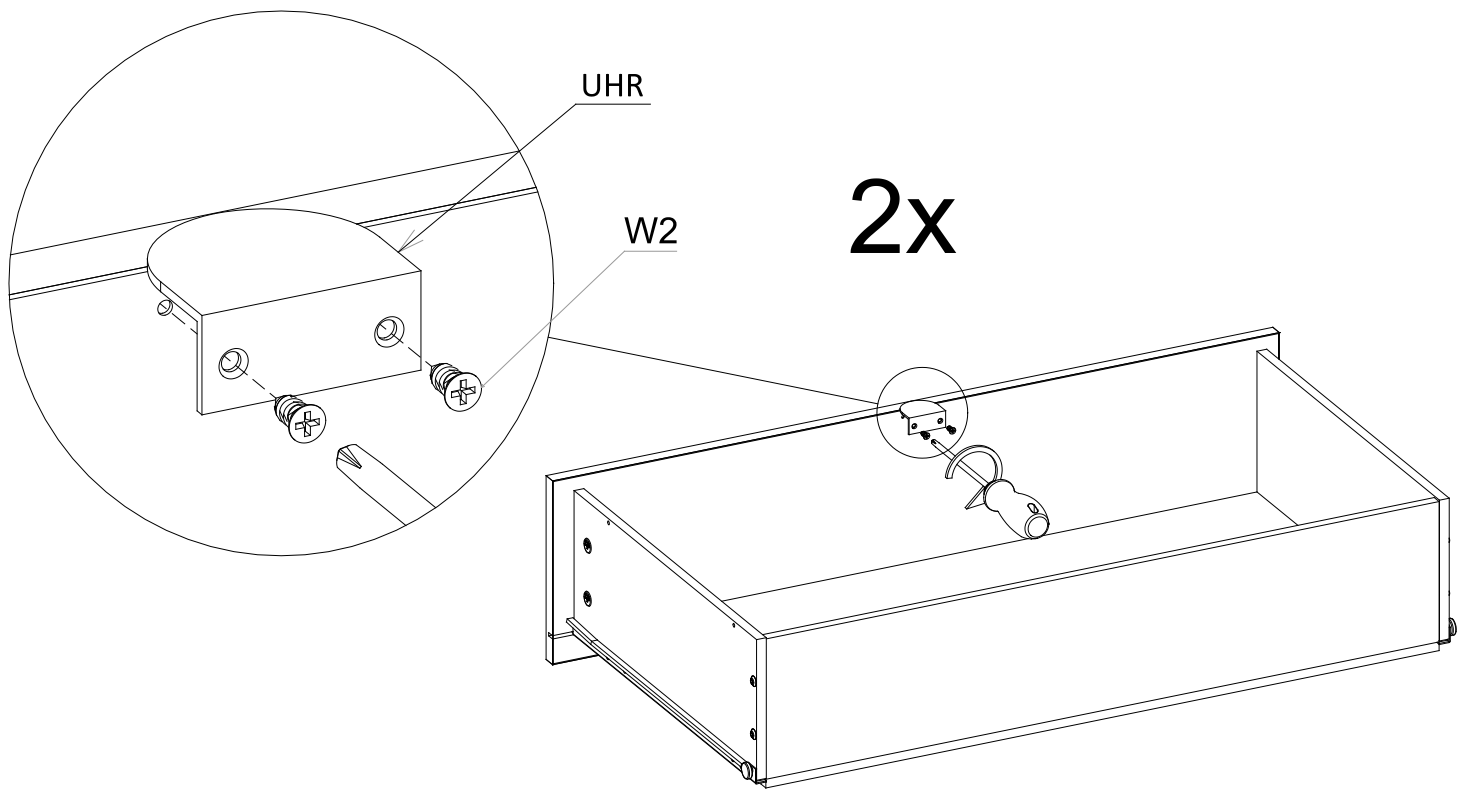
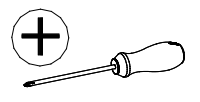

29

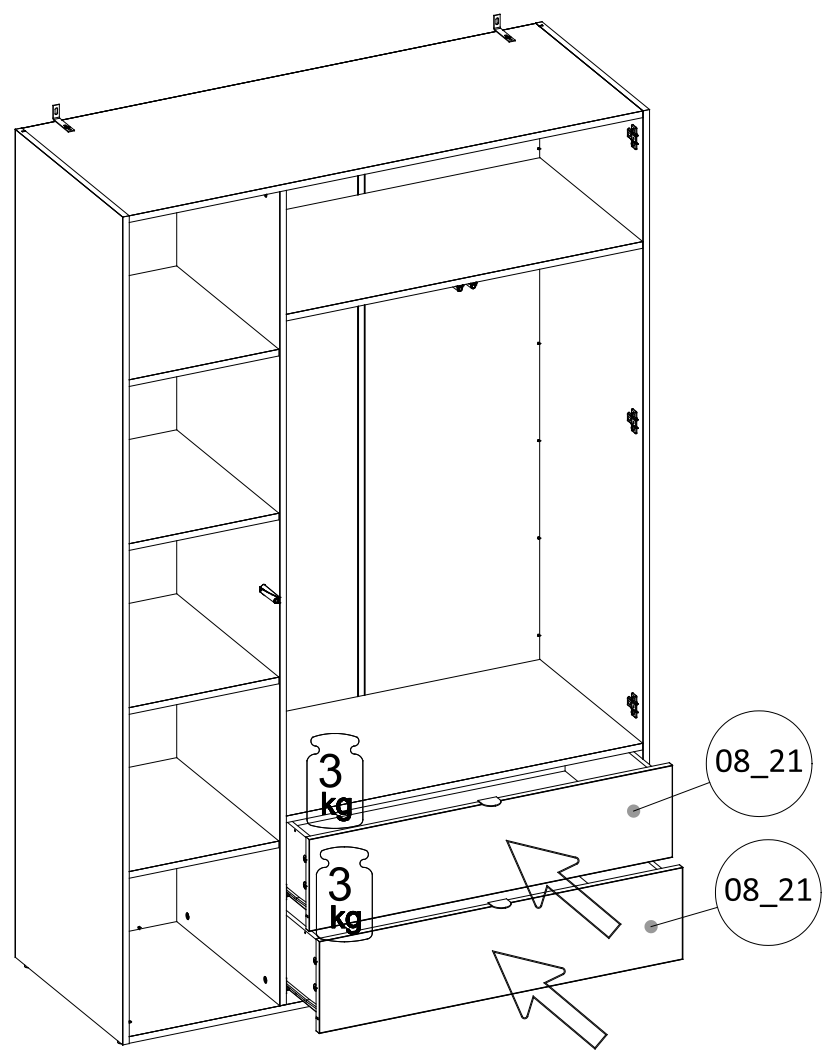
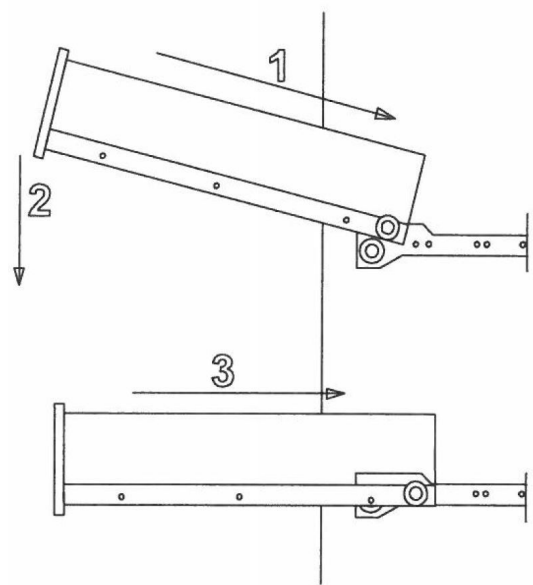

30

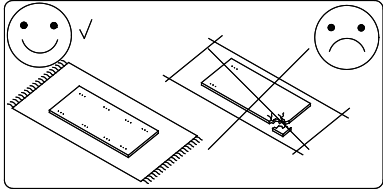
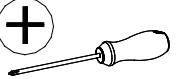
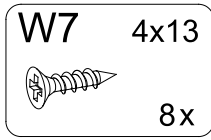
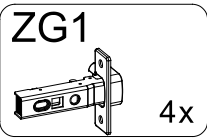

ZG1

W7

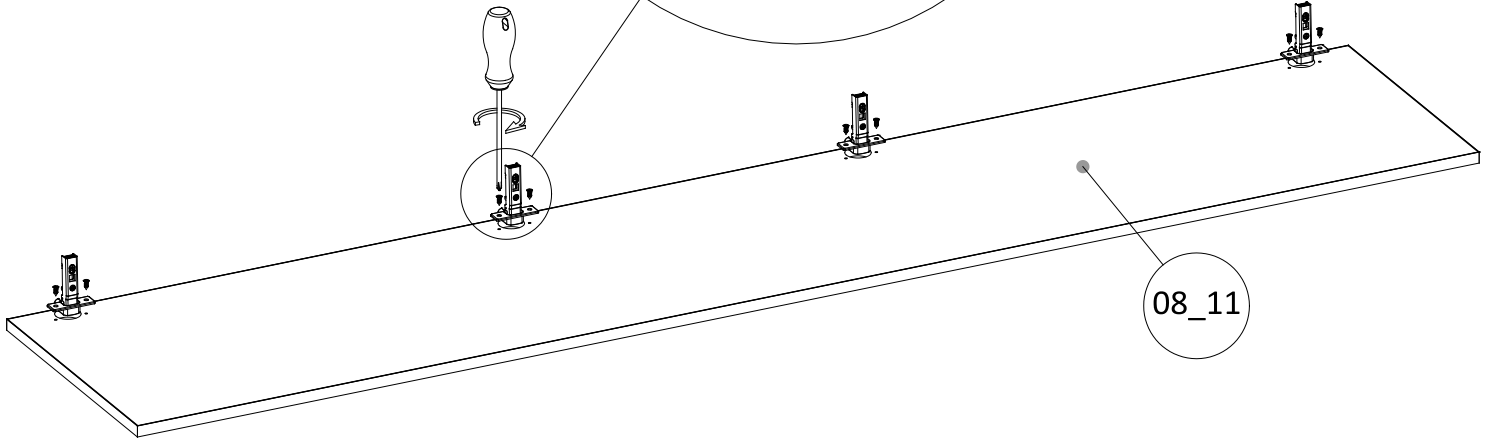

08_11

31

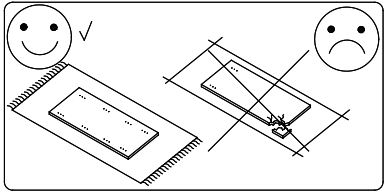
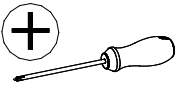
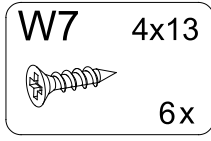
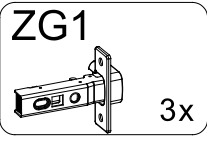

ZG1

W7

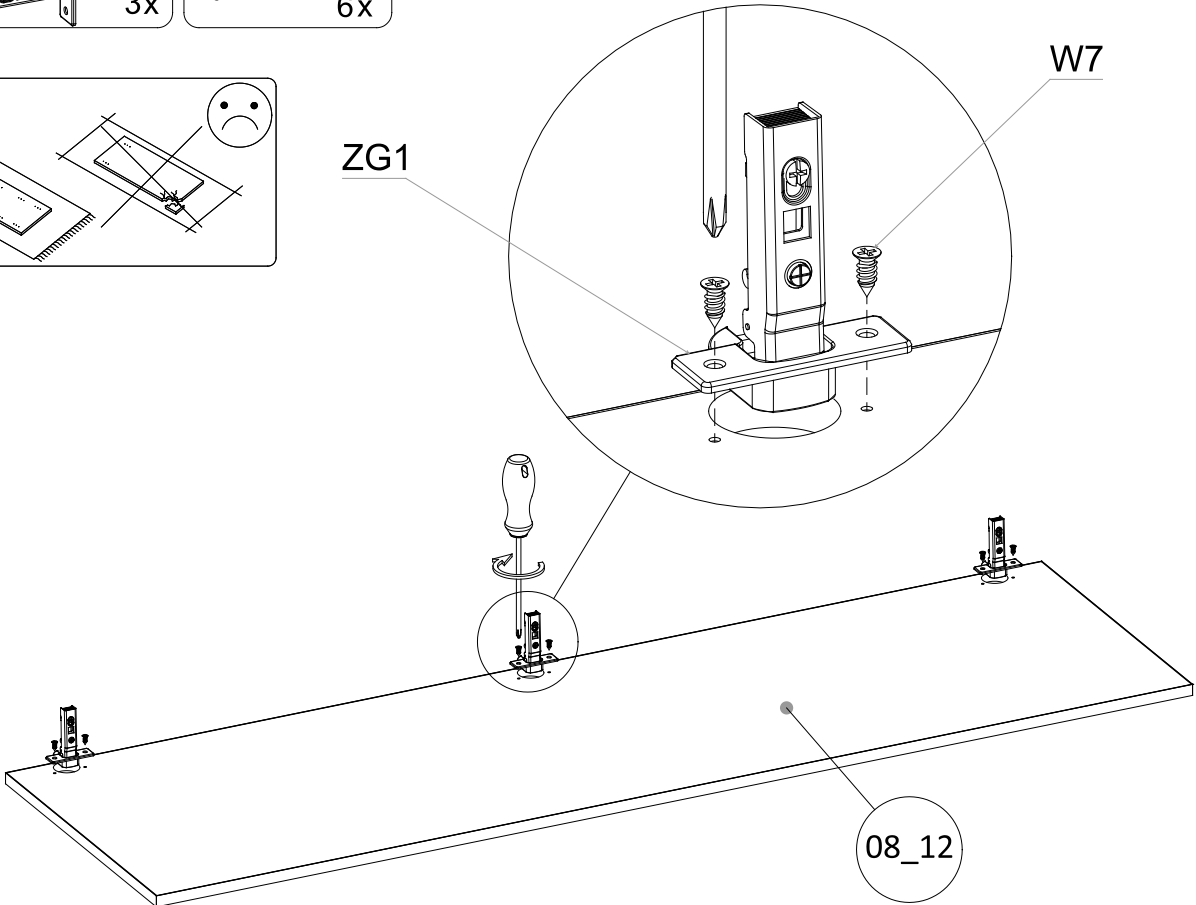

08_12

32

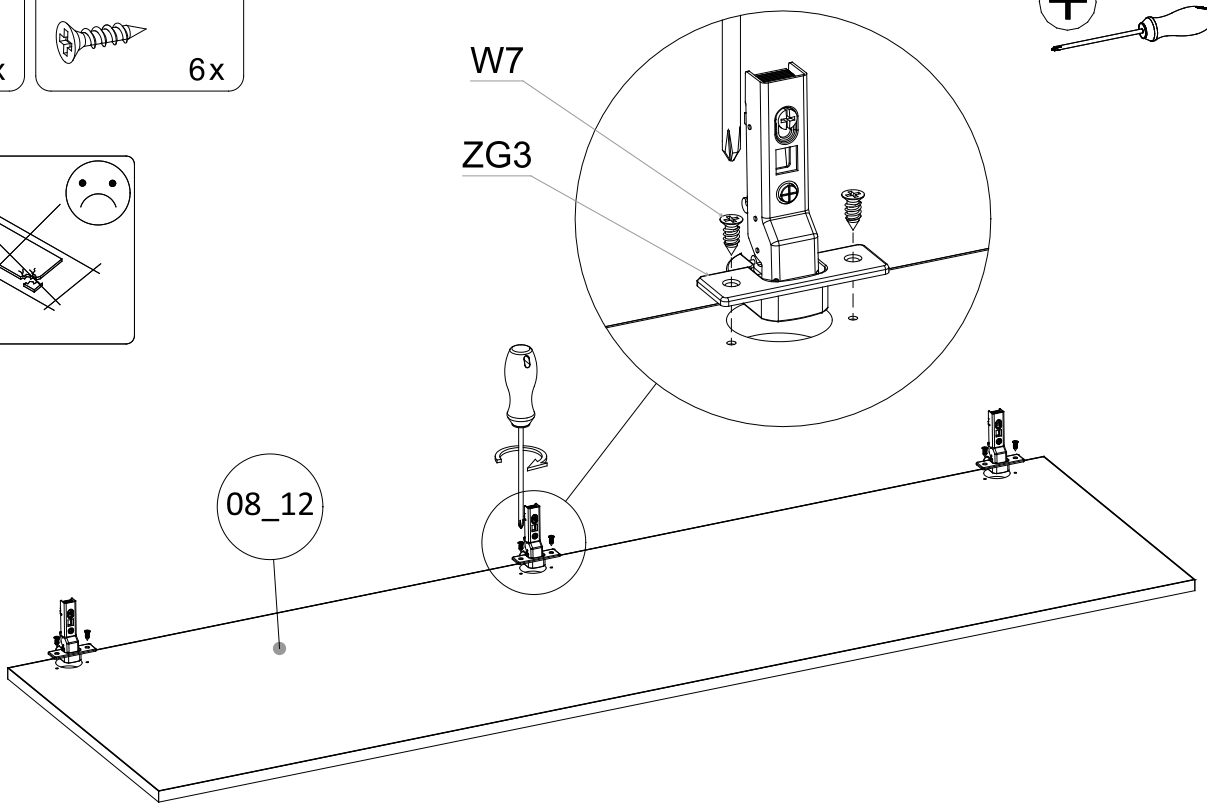
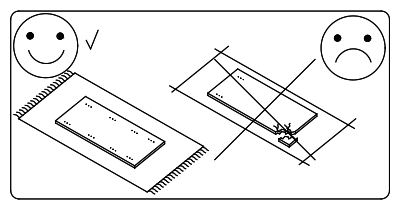
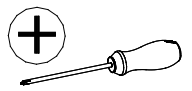
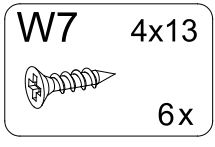
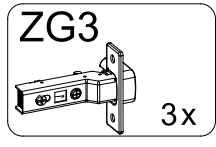

33

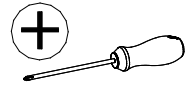

08_12 + ZG3

08_11

08_12 + ZG1

